

Schraubstöcke

Vices

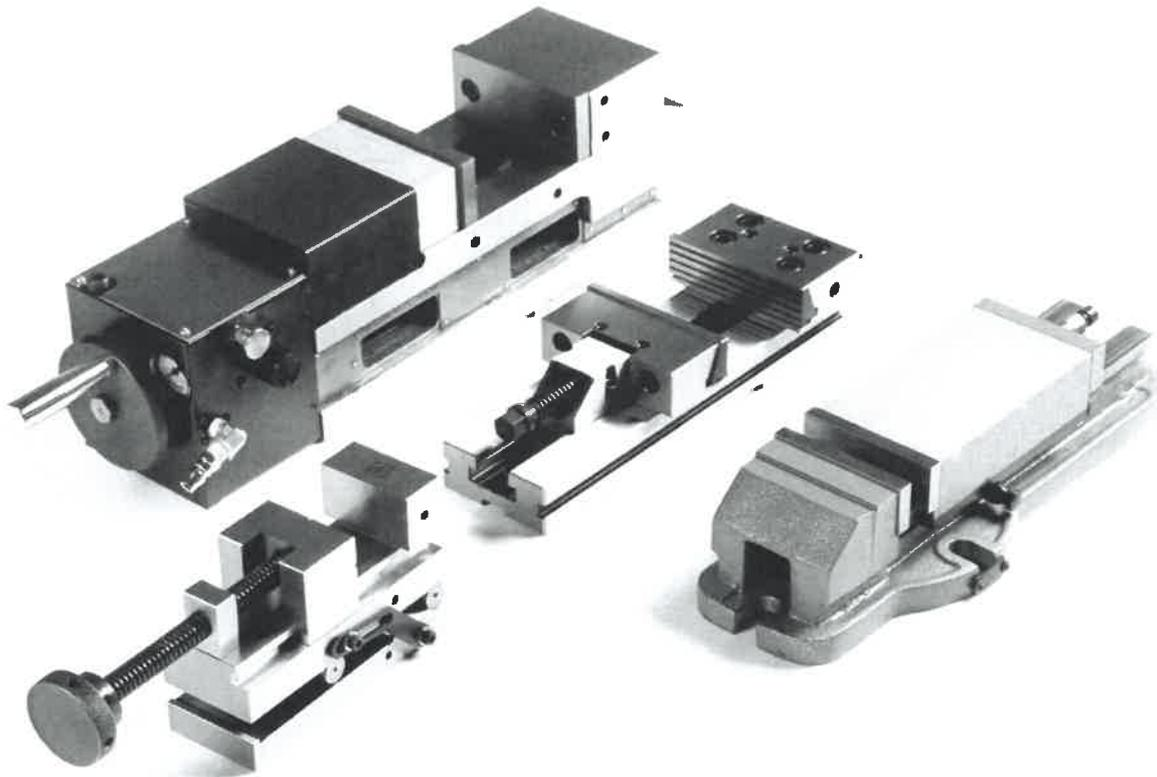

■ Inhalt:

- | Maschinenschraubstöcke Typ CMC / SVC
- | Doppelspanner
- | Doppel-Zentrischspanner
- | Pneumatikspanner
- | Mehrfach-Spanneinrichtung
- | NC-Spanner
- | Mechanische und hydraulische Maschinenschraubstöcke
- | Fräsmaschinenschraubstöcke
- | 3-Achsen-Schraubstock
- | Bohrmaschinenschraubstöcke
- | Werkbankschraubstöcke
- | Zentrischspanner
- | 5-Achsen-Zentrischspanner
- | Schleifschraubstöcke
- | Sinus-Schraubstöcke
- | Erodierschraubstöcke
- | Präzisions-Schraubstöcke CARMINATI
MOREE
- | Universal-Werkstückanschläge
- | Universal Aufsatzprismenbacken

■ Content:

- | Precision machine vices type CMC / SVC
- | Double vices
- | Double-self-centering vice
- | Pneumatic vices
- | Multiflex vices
- | NC-vices
- | Mechanical and hydraulic machine vices
- | Milling machine vices
- | 3-axes machine vices
- | Drilling machine vices
- | Table vices
- | Self-centering vices
- | 5-axes self-centering vices
- | Tool maker vices
- | Sinus vices
- | Erosion vices
- | Precision vices CARMINATI
MOREE
- | Stop-dogs
- | Universal prism jaws

Maschinenschraubstöcke Typ CMC / SVC

Precision machine vices type CMC / SVC

Präzisions-Maschinenschraubstock Typ CMC

Precision machine vice type CMC

- Führungsflächen gehärtet
 - mit Niederzugeffekt
 - modulares System
 - Parallelität < 0,005 / 100 mm
 - Rechtwinkligkeit < 0,02 / 50 mm
 - Wiederholgenauigkeit < 0,02 mm
 - feste Backe um 180° drehbar, Rückseite mit Spannstufe
 - auch als Doppelspanner erhältlich, siehe Seite 136 (Typ DZM)
- hardened slideways
 - with pull-down mechanism
 - modular system
 - parallelism < 0,005 / 100 mm
 - perpendicularity < 0,02 / 50 mm
 - repeatability < 0,02 mm
 - fixed jaw rotatable by 180°, reverse with step
 - also available as double-self-centering-vice, see page 136 (Typ DZM)



Drehplatte optional / Swivel plate optional

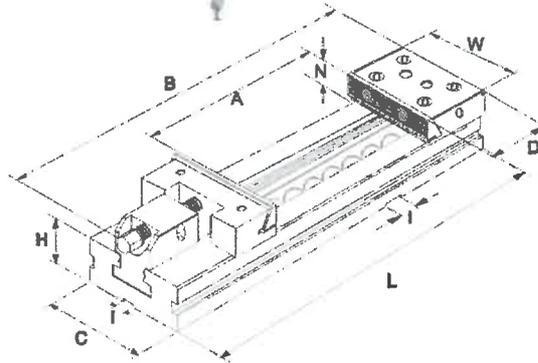

W mm	A mm	L mm	B mm	C mm	D mm	H mm	I mm	N mm	Max. Anz. moment / Max. torque Nm	Max. Spann- kraft / Clamping force daN	kg	Art.-Nr. / Order no.
100	100	270	320	75	77,9	35	16	30	30	3000	7	ZE-CMC-100/100
125	150	345	410	95	77,9	40	16	40	40	3000	13	ZE-CMC-125/150
150	200	420	500	125	89,4	50	16	50	60	5000	26	ZE-CMC-150/200
150	300	520	600	125	89,4	50	16	50	60	5000	29	ZE-CMC-150/300
175	200	455	530	145	96,8	58	16	60	60	6000	37	ZE-CMC-175/200
175	300	555	630	145	96,8	58	16	60	60	6000	42	ZE-CMC-175/300
175	400	655	730	145	96,8	58	16	60	60	6000	47	ZE-CMC-175/400
200	200	495	580	170	113	70	16	65	80	10000	64	ZE-CMC-200/200
200	300	595	680	170	113	70	16	65	80	10000	69	ZE-CMC-200/300
200	400	695	780	170	113	70	16	65	80	10000	74	ZE-CMC-200/400
200	500	795	880	170	113	70	16	65	80	10000	84	ZE-CMC-200/500
300	300	635	730	195	120	78	16	80	80	10000	105	ZE-CMC-300/300
300	400	735	830	195	120	78	16	80	80	10000	115	ZE-CMC-300/400

Inkl. Spannpratzen, Passsteine, Schlüssel, Handkurbel und Werkstückanschlag
Incl. brackets, T-nuts, wrench, crank and work piece stop

Maschinenschraubstöcke Typ CMC / SVC

Precision machine vices type CMC / SVC

Präzisions-Maschinenschraubstock mit Schnellverstellung Typ SVC

Precision machine vice with quick adjustment type SVC

- wie Typ CMC, jedoch mit Schnellverstellung
- as type CMC, but with quick adjustment

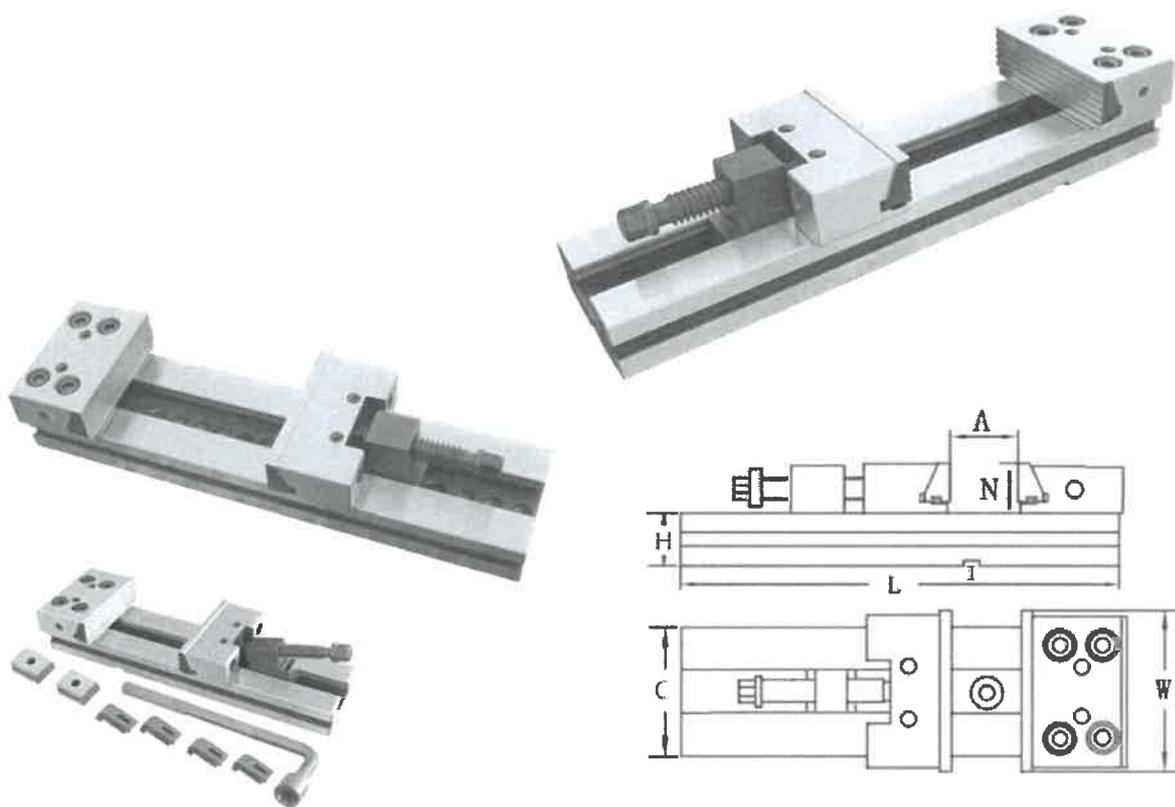

W mm	A mm	L mm	C mm	H mm	N mm	I mm	Max. Anz. moment / Max. torque Nm	Max. Spann- kraft / Clamping force daN	kg	Art.-Nr. / Order no.
100	100	270	75	35	30	16	30	3000	7	ZE-SVC-100/100
125	150	345	95	40	40	16	40	3000	13	ZE-SVC-125/150
150	200	420	125	50	50	16	60	5000	26	ZE-SVC-150/200
150	300	520	125	50	50	16	60	5000	29	ZE-SVC-150/300
175	300	555	145	58	60	16	60	6000	42	ZE-SVC-175/300
200	200	495	170	70	65	16	80	10000	64	ZE-SVC-200/200
200	300	595	170	70	65	16	80	10000	69	ZE-SVC-200/300
200	400	695	170	70	65	16	80	10000	74	ZE-SVC-200/400

Inkl. Spannpratzen, Passsteine, Schlüssel und Handkurbel
Incl. brackets, T-nuts, wrench and crank

Geteilte Schraubstöcke Typ CMC Modular vices type CMC

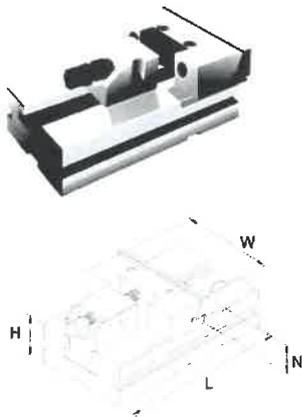

Bewegliches Element Typ CMC Movable jaw section type CMC

- speziell zum Spannen übergroßer Werkstücke
- vielseitige Spannmöglichkeiten
- for clamping oversized work pieces
- various clamping possibilities

W mm	N mm	L mm	H mm	kg	Art.-Nr. / Order no.
100	30	140	35	4	ZE-GS-B100
125	40	160	40	6	ZE-GS-B125
150	50	230	50	14	ZE-GS-B150
175	60	240	58	21	ZE-GS-B175
200	65	300	70	35	ZE-GS-B200

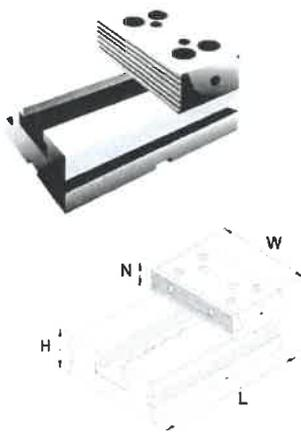

Festes Element Typ CMC Fixed jaw section type CMC

W mm	N mm	L mm	H mm	kg	Art.-Nr. / Order no.
100	30	140	35	4	ZE-GS-F100
125	40	160	40	6	ZE-GS-F125
150	50	230	50	13	ZE-GS-F150
175	60	240	58	18	ZE-GS-F175
200	65	300	70	30	ZE-GS-F200

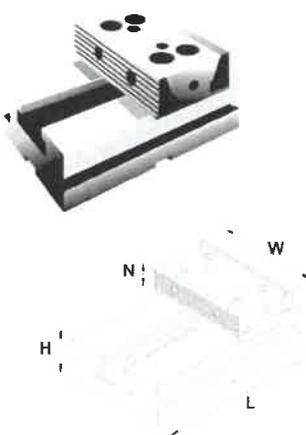

Festes Element doppelt Typ CMC Double fixed jaw section type CMC

- mit beidseitiger Spannmöglichkeit
- with double-sided clamping possibility

W mm	N mm	L mm	H mm	kg	Art.-Nr. / Order no.
100	30	140	35	4	ZE-GS-D100
125	40	160	40	6	ZE-GS-D125
150	50	230	50	13	ZE-GS-D150
175	60	240	58	19	ZE-GS-D175
200	65	300	70	30	ZE-GS-D200

Zubehör für Typ CMC / SVC Accessories for type CMC / SVC

Drehplatte Swivel plate



passend zu / suitable for	Art.-Nr. / Order no.
100	ZE-CMC-100D
125	ZE-CMC-125D
150	ZE-CMC-150D
175	ZE-CMC-175D
200	ZE-CMC-200D
300	ZE-CMC-300D

Preis pro Stück / Price per piece

Rillenbacke Grooved jaw



passend zu / suitable for	Art.-Nr. / Order no.
100	ZE-CMC-100RB
125	ZE-CMC-125RB
150	ZE-CMC-150RB
175	ZE-CMC-175RB
200	ZE-CMC-200RB
300	ZE-CMC-300RB

Preis pro Stück / Price per piece

Glatte Backe Plain jaw



passend zu / suitable for	Art.-Nr. / Order no.
100	ZE-CMC-100GB
125	ZE-CMC-125GB
150	ZE-CMC-150GB
175	ZE-CMC-175GB
200	ZE-CMC-200GB
300	ZE-CMC-300GB

Preis pro Stück / Price per piece

Weiche Backe Soft machinable jaw



passend zu / suitable for	Art.-Nr. / Order no.
100	ZE-CMC-100WB
125	ZE-CMC-125WB
150	ZE-CMC-150WB
175	ZE-CMC-175WB
200	ZE-CMC-200WB
300	ZE-CMC-300WB

Preis pro Stück / Price per piece

Spannbacke überhoch Extra-high jaw



passend zu / suitable for	Art.-Nr. / Order no.
100	ZE-CMC-100GH
125	ZE-CMC-125GH
150	ZE-CMC-150GH
175	ZE-CMC-175GH
200	ZE-CMC-200GH

Preis pro Stück / Price per piece

Prismenbacke Prism jaw



passend zu / suitable for	Art.-Nr. / Order no.
100	ZE-CMC-100PB
125	ZE-CMC-125PB
150	ZE-CMC-150PB
175	ZE-CMC-175PB
200	ZE-CMC-200PB

Preis pro Stück / Price per piece

Koordinaten-Prismenbacke Prismatic stack type jaw



passend zu / suitable for	Art.-Nr. / Order no.
100	ZE-CMC-100KB
125	ZE-CMC-125KB
150	ZE-CMC-150KB
175	ZE-CMC-175KB
200	ZE-CMC-200KB
300	ZE-CMC-300KB

Preis pro Stück / Price per piece

Niederzugbacke Pull-down jaw



passend zu / suitable for	Art.-Nr. / Order no.
100	ZE-CMC-100NB
125	ZE-CMC-125NB
150	ZE-CMC-150NB
175	ZE-CMC-175NB
200	ZE-CMC-200NB
300	ZE-CMC-300NB

Preis pro Stück / Price per piece

Niederzugbacke überhoch Extra-high pull down jaw



passend zu / suitable for	Art.-Nr. / Order no.
100	ZE-CMC-100NH
125	ZE-CMC-125NH
150	ZE-CMC-150NH
175	ZE-CMC-175NH
200	ZE-CMC-200NH
300	ZE-CMC-300NH

Preis pro Stück / Price

Doppelspanner Double vices

Doppelspanner Typ TLD Double vices type TLD

- mechanisch
 - zentrisches Spannen von 2 Werkstücken gleicher oder unterschiedlicher Größe
 - Führungsflächen gehärtet
 - mit Niederzugeffekt
 - 6 verschiedene Spannmöglichkeiten
 - einfahrbare Spindel (nur Typ TLD-150), komplett abgedeckt
- mechanically
 - self centering for 2 work pieces of same or different size hardened slideways
 - with pull-down mechanism
 - 6 clamping options
 - retractable spindle (only type TLD-150), completely covered

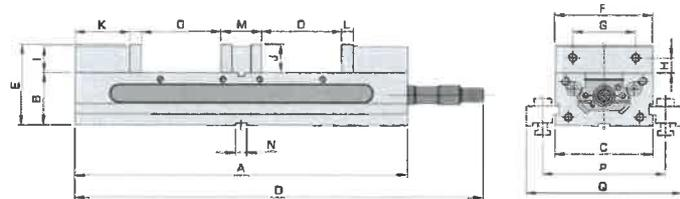
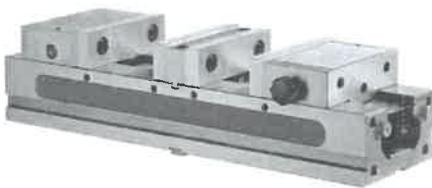

Typ / Type	A	B	C	D	E	F	G	H	I	J	K	L	M	N	O	P	Q	Max. Spann- kraft / Clamping force daN	kg	Art.-Nr. / Order no.
100	405	63,5	104	459	101,5	102	63,5	17,5	33	38	69	15	55	18	90	143	195	2600	20	ZE-TLD-100
150	520	82,5	154	536	127	152	98,4	23,8	41,5	44,5	86,5	18	66	18	125	193	245	3000	52	ZE-TLD-150

Passende Nutensteine lieferbar auf Anfrage
Suitable t-nuts available upon request

Doppel-Zentrischspanner, Typ DZM Double-self-centering vice, type DZM

- wie Typ CMC (Seite 132), jedoch zum Spannen von 2 Werkstücken
- as type CMC (page 132), but for clamping 2 workpieces

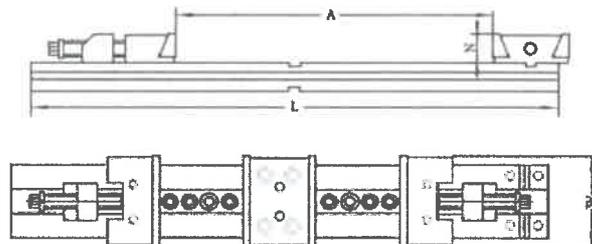

W mm	A mm	L mm	N mm	kg	Art.-Nr. / Order no.
175	120	666	60	63	ZE-DZM-175/120
175	170	766	60	67	ZE-DZM-175/170
200	150	805	65	100	ZE-DZM-200/150
200	206	905	65	108	ZE-DZM-200/200

Inkl. Spannpratzen, Passsteine, Schlüssel und Handkurbel
Incl. brackets, T-nuts, wrench and crank

Passende Ersatzbacken für den Typ ZE-DZM- siehe Seite 135
Suitable jaws for type ZE-DZM- see page 135

Pneumatikspanner

Pneumatic vices

Typ PSP

Type PSP

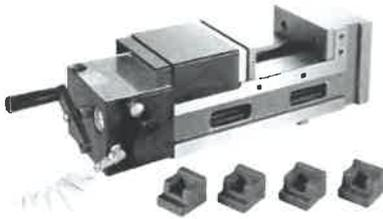

- Betätigung durch Pressluft
 - besonders geeignet für Serienfertigung auf Maschinenzentren, Fräs- und Bohrmaschinen und Sondermaschinen
 - mit Niederzugeffekt
 - Taktzeit nur 1,5 s
 - Hub bis 8 mm
 - einstellbar von 0-4000 kg/cm²
- operated by compressed air
 - suitable for mass production and for machine centers, milling, drilling and special-purpose machines
 - with pull-down mechanism
 - cycle speed 1,5 s
 - clamping stroke up to 8 mm
 - capacity from 0-4000 kg/cm²

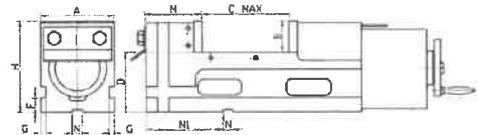
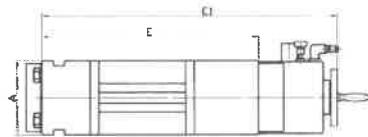

Typ / Type	A mm	B mm	Cmax mm	D mm	E mm	E1 mm	F mm	G mm	H mm	M mm	N mm	N1 mm	Max. Spann- kraft / Clamping force daN	kg	Art.-Nr. / Order no.
130/150	130	55	150	105	380	520	25	9	160	100	18	136	6000	41	ZE-PSP-130/150
160/160	160	58	160	105	400	540	25	9	163	100	18	136	6000	50	ZE-PSP-160/160
160/250	160	58	250	105	490	630	25	9	163	100	18	136	6000	57	ZE-PSP-160/250
180/200	180	63	200	110	460	600	25	12	173	108	18	171	9000	67	ZE-PSP-180/200
200/200	200	63	200	110	470	610	25	12	173	108	18	171	9000	77	ZE-PSP-200/200
200/300	200	63	300	110	570	710	25	12	173	108	18	171	9000	86	ZE-PSP-200/300

Pneumatischer Doppelspanner Typ DPSP

Pneumatic double vice type DPSP



- Betätigung durch Pressluft
 - mit Niederzugeffekt
 - mit 2 Spannstellen
 - Taktzeit nur 1,5 s
 - Hub bis 8 mm
 - Werkstücke unterschiedlicher Größe (bis 5 mm) spannbar
 - einstellbar von 0-4000 kg/cm²
- operated by compressed air
 - with pull-down mechanism
 - for 2 work pieces
 - cycle speed 1,5 s
 - clamping stroke up to 8 mm
 - work pieces of different sizes (up to 5 mm) can be clamped
 - capacity from 0-4000 kg/cm²

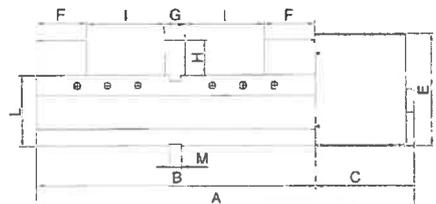
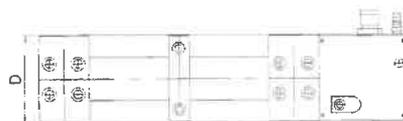

Typ / Type	A mm	B mm	C mm	D mm	E mm	F mm	G mm	H mm	I mm	L mm	M mm	Max. Spann- kraft / Clamping force daN	kg	Art.-Nr. / Order no.
115	556	410	146	130	166	74	30	52	0-115	105	18	3200	42	ZE-DPSP-130
150	656	510	146	160	168	82	30	55	0-155	105	18	4000	67	ZE-DPSP-160

Mehrfach-Spanneinrichtungen

Multiflex vices

Typ MFS Type MFS

- zum Spannen von mehreren Werkstücken
- variable Anpassung der Spannelemente an die Werkstückabmessungen
- optimale Nutzung des Arbeitsbereichs einer Maschine
- horizontal einsetzbar
- mit Skalierung auf Spannleiste
- Lieferumfang: 1 Spannleiste, 1 feste Backe (glatt), 3 (bis L = 500 mm) oder 4 (ab L = 600 mm) Spannbacken (glatt)
- for clamping of multiple work pieces
- each clamping element individually adjustable
- optimum exploitation of machine's work-space
- for horizontal applications
- with scale for ease of handling
- scope of delivery: 1 clamping bar, 1 fixed jaw (plain), 3 (up to L = 500 mm) or 4 (from L = 600 mm) clamping jaws (plain)

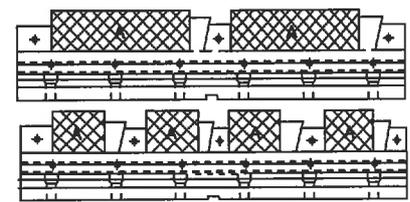
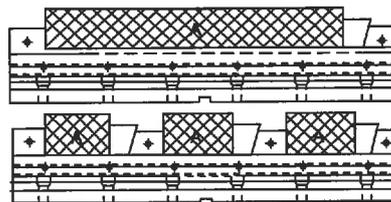
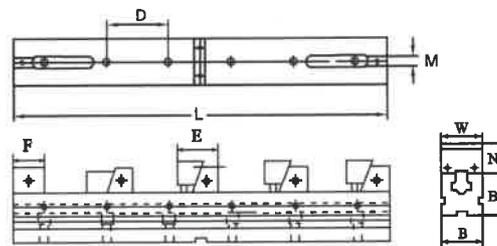
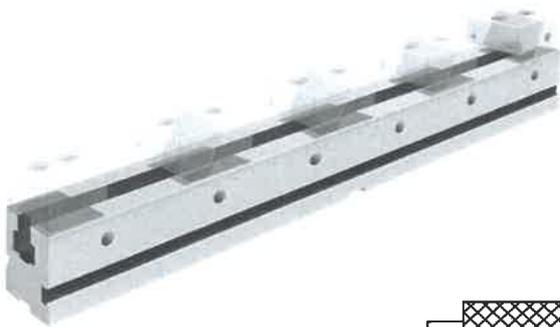

B mm	L mm	W mm	D mm	F mm	E mm	N mm	M mm	1xA	2xA	3xA	4xA	Max. Spann- kraft / Clamping force daN	Art.-Nr. / Order no.
50	300	49	100	38	55 - 58	25	16	208	75	30	8	1000	ZE-MFS-50/300
	400							125	64	33	ZE-MFS-50/400		
	500							175	96	58	ZE-MFS-50/500		
	600							225	129	83	ZE-MFS-50/600		
	700							275	161	108	ZE-MFS-50/700		
75	400	74	100	50	70 - 75	40	16	275	100	41	12	1500	ZE-MFS-75/400
	500							150	75	37	ZE-MFS-75/500		
	600							200	108	62	ZE-MFS-75/600		
	700							250	141	87	ZE-MFS-75/700		
	800							675	300	174	112		ZE-MFS-75/800

Inkl. 4 Spannpratzen mit Nutensteinen und Schrauben, 2 Passteine, 4 Werkstückanschläge, Spannschlüssel
Incl. 4 brackets, t-nuts, screws, 2 piece stops, 4 piece stops and wrench

Ersatzbacken für Typ MFS Spare jaws for type MFS

Feste Backe, Stück Fixed jaw, piece



Für Typ / For type	Breite / Width mm	Länge / Length mm	kg	Art.-Nr. / Order no.
MFS50	49	38	0,4	 ZE-MFS-50FB
MFS75	74	50	1,3	 ZE-MFS-75FB

Bewegliche Backe, glatt, Stück Movable jaw, plain, piece



Für Typ / For type	Breite / Width mm	Länge / Length mm	kg	Art.-Nr. / Order no.
MFS50	49	55 / 58	0,6	 ZE-MFS-50GB
MFS75	74	70 / 75	1,8	 ZE-MFS-75GB

Bewegliche Backe, geriffelt, Stück Movable jaw, serrated, piece



Für Typ / For type	Breite / Width mm	Länge / Length mm	kg	Art.-Nr. / Order no.
MFS50	49	55 / 58	0,6	 ZE-MFS-50RB
MFS75	74	70 / 75	1,8	 ZE-MFS-75RB

Bewegliche Backe, extrabreit, glatt, Stück Movable jaw, enlarged, plain, piece



Für Typ / For type	Breite / Width mm	Länge / Length mm	kg	Art.-Nr. / Order no.
MFS50	63	56	1,1	 ZE-MFS-50XLB
MFS75	109	60	3	 ZE-MFS-75XLB

NC Schraubstöcke Typ MC2

NC precision power vices type MC2

Präzisions-Hochdruckspanner mit mechanischer Kraftverstärkung

High-power vice with mechanical force intensifier

Vorwahlstufe / Pre-selection	Spannkraft / Clamping force Typ / Type 125	Spannkraft / Clamping force Typ / Type 160	Spannkraft / Clamping force Typ / Type 200
0	500 daN	500 daN	500 daN
1	1100 daN	1300 daN	1500 daN
2	2500 daN	2700 daN	3200 daN
3	3700 daN	4000 daN	5100 daN
4	5000 daN	5400 daN	6800 daN



Typ MC2 type MC2

- Sphäroguss FCD60
- unten und seitlich geschliffen
- Anti-Lift-Mechanismus
- eingebauter Niederzug
- mechanische Kraftverstärkung, dichtunglos
- kurze Bauart
- Spannkraft voreinstellbar
- ductile iron FCD60
- steel body, ground below and side-ways
- "Anti-lifting" mechanism
- integrated pull down
- mechanical force increase, no seals required
- short body
- pre-selection of clamping force

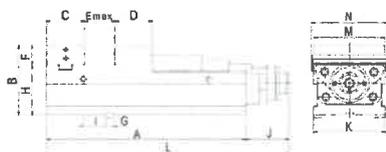

Typ MC2 / Type MC2	A mm	B mm	C mm	D mm	E _{max} mm	F mm	G mm	H mm	I mm	J mm	K mm	L mm	M mm	N mm	kg	Art.-Nr. / Order no.
125	365	145	78	74	208	45	18	100	57	98,5	126	463,5	125	135	35	14-MC2-125
160	455	160	86	86	275	45	18	115	49	98,5	162	553,5	160	171	57	14-MC2-160
160M	480	160	86	86	300	45	18	115	49	98,5	162	578,5	160	174	63	14-MC2-160M
200	505	180	100	97	300	55	18	125	66	100	202	603,5	200	211	90	14-MC2-200

Inkl. 4 Spannpratzen, Hebeösen, Schlüssel und Nutensteine
Incl. clamping brackets, eye bolts, keys and t-nuts



Typ MC2 lang type MC2 long

- lange Version des Typs MC2
- extra große Spannweite
- long version of type MC2
- with large opening range

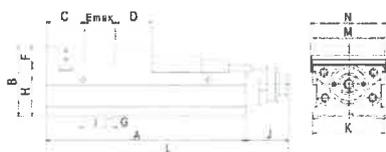

Typ MC2 / Type MC2	A mm	B mm	C mm	D mm	E _{max} mm	F mm	G mm	H mm	I mm	J mm	K mm	L mm	M mm	N mm	kg	Art.-Nr. / Order no.
160L	535	160	86	86	355	45	18	115	49	98,5	162	633,5	160	174	64	14-MC2-160L
200L	610	180	100	97	405	55	18	125	66	100	202	708,5	200	214	103	14-MC2-200L

Inkl. 4 Spannpratzen, Hebeösen, Schlüssel und Nutensteine
Incl. clamping brackets, eye bolts, keys and t-nuts

Ersatzbacken für Schraubstöcke Typ MC2

Spare jaws for vices type MC2

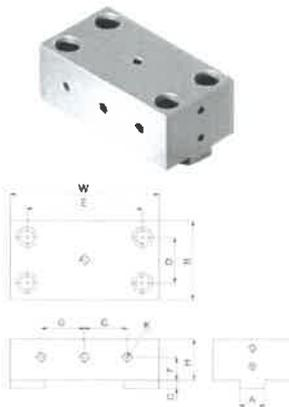

Feste Blockbacke, Stück

Fixed jaw, piece

Größe / Size	A mm	B mm	C mm	D mm	E mm	H mm	W mm	Art.-Nr. / Order no.
125	24	78	8	45	88	45	125	14-HJ-125
160	28	86	9	50	124	45	160	14-HJ-160
200	28	100	9	62	140	55	200	14-HJ-200

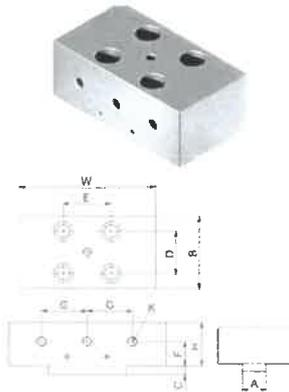

Bewegliche Blockbacke, Stück

Movable jaw, piece

Größe / Size	A mm	B mm	C mm	D mm	E mm	H mm	W mm	Art.-Nr. / Order no.
125	24	76	8	42	35	45	125	14-BHJ-125
160	28	86	9	50	56	45	160	14-BHJ-160
200	28	98	9	59	62	55	200	14-BHJ-200

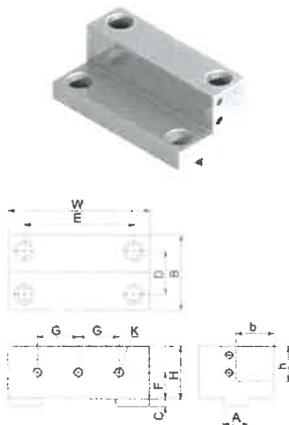

Feste Stufenbacke, Stück

Stepped jaw, fixed, piece

Größe / Size	A mm	B mm	b mm	C mm	D mm	E mm	H mm	h mm	W mm	Art.-Nr. / Order no.
125	24	78	38	8	45	88	50	32	126	14-LJ-125
160	28	86	43	8	50	124	60	40	160	14-LJ-160
200	28	98	49	9	62	140	70	45	200	14-LJ-200

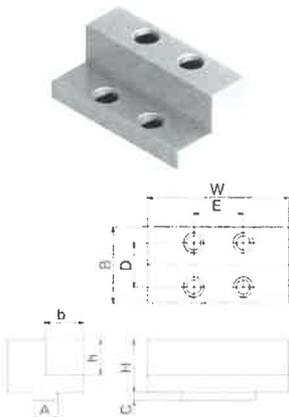

Bewegliche Stufenbacke, Stück

Stepped jaw, movable, piece

Größe / Size	A mm	B mm	b mm	C mm	D mm	E mm	H mm	h mm	W mm	Art.-Nr. / Order no.
125	24	76	38	8	42	35	50	32	125	14-BLJ-125
160	28	86	43	8	50	56	60	40	160	14-BLJ-160
200	28	98	49	9	59	62	70	45	200	14-BLJ-200

Weitere Ersatzbacken auf Anfrage
Further jaws available upon request

Ersatzbacken für Schraubstöcke Typ MC2

Spare jaws for vices type MC2

Prismenbacke, Stück

Prism jaw, piece

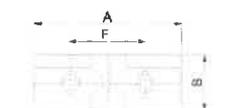

Größe / Size	A mm	B mm	C mm	D mm	E mm	F mm	G	Art.-Nr. / Order no.
125	125	47	25	30	25	64	M8	14-PB-125
160	160	62	30	30	30	92	M10	14-PB-160
200	200	72	30	30	30	100	M10	14-PB-200

Koordinaten-Prismenbacke, Stück

V-jaw, piece

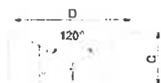

Größe / Size	A mm	B mm	C mm	D mm	E mm	F	Art.-Nr. / Order no.
125	125	47	50	110	64	M8	14-KB-125
160	160	62	55	130	92	M10	14-KB-160
200	200	72	55	130	100	M10	14-KB-200

Weitere Ersatzbacken auf Anfrage
Further jaws available upon request

Schraubstöcke Typ FHS2

Vices type FHS2



Hydraulischer Maschinenschraubstock Typ FHS2

Hydraulic machine vice type FHS2

- robuste Bauart mit mechanisch-hydraulischer Hochdruckspindel und großer Spannweite
- hohe Spanngenauigkeit
- Schnellverstellung durch Steckbolzen
- alle Verschleißteile sind gehärtet, deshalb sowohl für schwere als auch leichte Zerspannung verwendbar
- sturdy design with hydraulic high-pressure spindle, mechanical drive and large clamping capacity
- high accuracy
- rapid clamping range adjustment with socket pins
- all wearing parts are hardened, therefore suitable for heavy- and light-duty machining operations

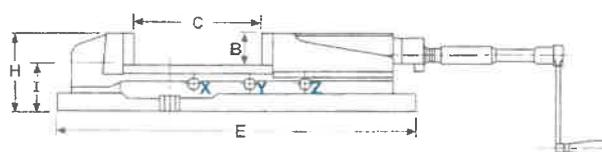
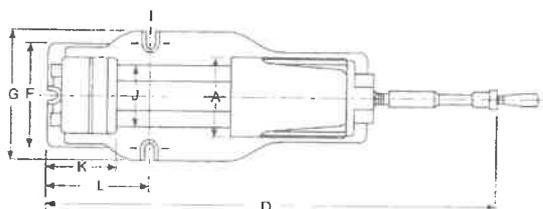

Typ / Type	A mm	B mm	C mm	D mm	E mm	F mm	G mm	H mm	I mm	J mm	K mm	L mm	Spannbereich / Clamping range mm			Spannkraft / Clamping force daN	kg	Art.-Nr. / Order no.
													X	Y	Z			
FHS 100	105	36	170	695	440	135	170	95	58	80	95	147	0-57	55-114	112-170	2500	21	14-FHS2-100
FHS 125	130	48	220	840	550	175	207	120	70,5	97	107	195	0-73	72-146	145-220	3500	38	14-FHS2-125
FHS 150	150	53	300	970	620	182	225	135	82,5	116	117	210	0-100	98-200	198-300	4500	53	14-FHS2-150
FHS 200	200	62	300	1070	680	260	280	162	100	160	150	260	0-100	99-200	198-300	8000	95	14-FHS2-200

Inkl. Kurbel, Verlängerung und glatten Backen
Incl. hand crank, extension and plain jaws

1.

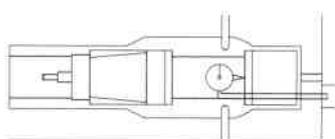

2.

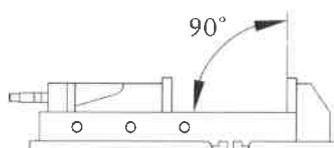

3.

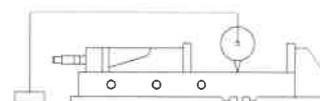

1	Parallelität der festen Backe zur Stirnseite / Parallelism of body face and fixed jaw clamp face	0,01 mm
2	Rechtwinkligkeit feste Backe zu Führungsbahn / Squareness of fixed jaw and jaw slideway	0,02 mm
3	Parallelität Auflagefläche zu Führungsbahn / Parallelism of body bottom face and jaw slideway	0,01 mm

Zubehör für Typ FHS2 Accessories for type FHS2



Drehplatte Swivel plate

Für Größe /
For size

Art.-Nr. /
Order no.

100	14-FHS2-100/S
125	14-FHS2-125/S
150	14-FHS2-150/S
200	14-FHS2-200/S



Glatte Backen, Satz Plain jaws, set

Für Größe /
For size

Art.-Nr. /
Order no.

100	14-FHS2-100/GB
125	14-FHS2-125/GB
150	14-FHS2-150/GB
200	14-FHS2-200/GB



Prismenbacken, Satz: 1 St. mit Prisma, 1 St. glatt Prism jaws, set: 1 pc. with prism, 1 pc. plain

Für Größe /
For size

Art.-Nr. /
Order no.

100	14-FHS2-100/PB
125	14-FHS2-125/PB
150	14-FHS2-150/PB
200	14-FHS2-200/PB

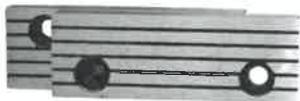

Rillenbacken, Satz Grooved jaws, set

Für Größe /
For size

Art.-Nr. /
Order no.

100	14-FHS2-100/RB
125	14-FHS2-125/RB
150	14-FHS2-150/RB
200	14-FHS2-200/RB



Dichtungssatz Set of seals

Für Größe /
For size

Art.-Nr. /
Order no.

100	14-FHS2-100/D
125	14-FHS2-125/D
150	14-FHS2-150/D
200	14-FHS2-200/D

Alle Ersatzteile ab Lager lieferbar. Technischer Service in unserem Hause
All spare parts available in stock. Company-own technical service

Schraubstöcke Typ NCK2

Vices type NCK2

Typ NCK2

Type NCK2

- mechanisch-hydraulisch
- eingebauter Niederzugeffekt
- mit Schnellverstellung
- Toleranz der Bauhöhe 0,02 mm, somit für den Einsatz mehrerer Schraubstöcke nebeneinander geeignet
- auch seitlich einsetzbar
- Bett gehärtet HRC 45°, Körper aus Guss FCD 60
- *mechanic-hydraulic*
- *with pull down mechanism*
- *with quick adjustment*
- *height tolerance = 0,02 mm, suitable for side by side application*
- *can also be laterally mounted*
- *hardened bed HRC 45°, body made from cast iron FCD 60*

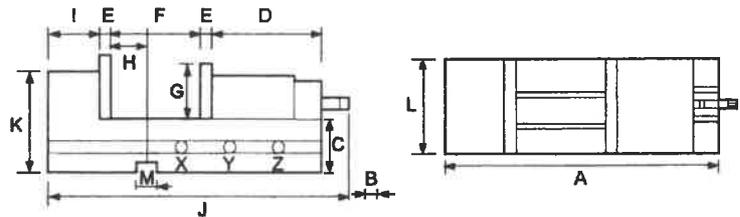

Typ / Type	A mm	B mm	C mm	D mm	E mm	Spannbereich / Clamping range F mm			G mm	H mm	I mm	J mm	K mm	L mm	M mm	f mm	daN	kg	Art.-Nr. / Order no.
						X	Y	Z											
100	404	14	62	208	12,5	0-85	85-170	-	42	45	64,5	450-540	102	105	16	50	2500	22	14-NCK2-100
150	507	19	85	243	15,5	0-90	90-180	180-270	57	65	84,5	620-710	140	152	18	90	5000	50	14-NCK2-150
200	606	19	95	257	18,5	0-100	100-200	200-300	62	82	89,5	655-755	162	200	18	150	7000	80	14-NCK2-200

Parallelität der festen Backe zur Stirnseite / <i>Parallelism of body face and fixed jaw clamp face</i>	0,01 mm
Rechtwinkligkeit feste Backe zu Führungsbahn / <i>Squareness of fixed jaw and jaw slideway</i>	0,015 mm
Parallelität Auflagefläche zu Führungsbahn / <i>Parallelism of body bottom face and jaw slideway</i>	0,01 mm
Max. Hub eines Referenzwerkstücks / <i>Max. lift of test block</i>	0,02 mm
Parallelität Referenzwerkstück zu Auflagefläche / <i>Parallelism of clamped test block and bottom face</i>	0,015 mm

Fräsmaschinenschraubstöcke

Milling machine vices

Typ MSK ohne Drehplatte, mechanisch

Type MSK without swivel plate, mechanical

- für Fräs-, Schleif- und Bohrarbeiten
- Backen gehärtet und geschliffen
- for milling, grinding and drilling operations
- jaws hardened and ground

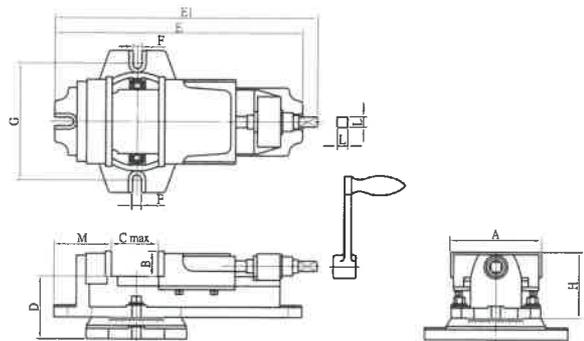
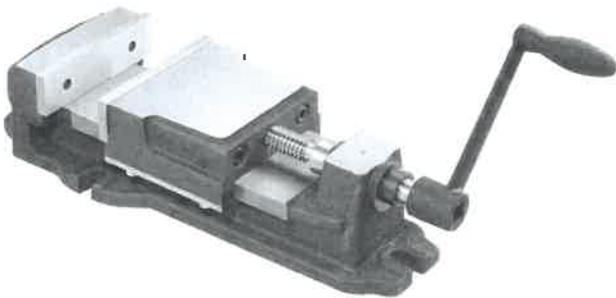

Typ / Type	A mm	B mm	Cmax mm	E mm	E1 mm	F mm	G mm	H mm	L mm	M mm	Max. Spann- kraft / Clamping force daN	kg	Art.-Nr. / Order no.
100	104	36	62	293	310	13	145	83	15	65	900	9	ZE-MSK100
125	130	37	82	362	384	13	172	97	15	84	900	15	ZE-MSK125
150	152	43	112	442	473	15	209	108	16,5	90	1000	26	ZE-MSK150
200	204	63	149	579	609	18	312	148	21	122	1400	53	ZE-MSK200

Typ MSK mit Drehplatte, mechanisch

Type MSK with swivel plate, mechanical

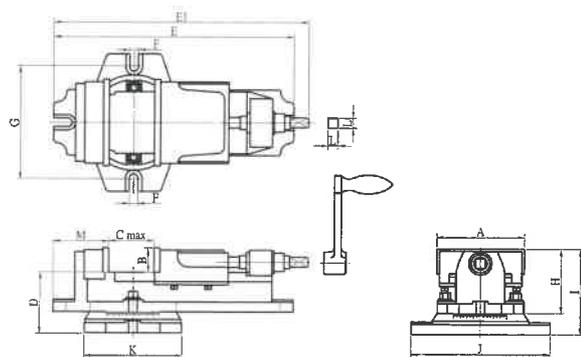
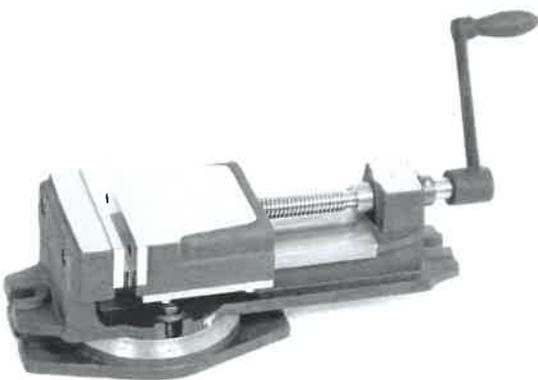

Typ / Type	A mm	B mm	Cmax mm	D mm	E mm	E1 mm	F mm	G mm	H mm	I mm	J mm	K mm	L mm	M mm	Max. Spann- kraft / Clamping force daN	kg	Art.-Nr. / Order no.
100	104	36	62	76	293	310	13	145	83	113	176	122	15	65	900	10	ZE-MSK100D
125	130	37	82	92	362	384	13	172	97	129	209	147	15	84	900	17	ZE-MSK125D
150	152	43	112	105	442	473	15	209	108	148	260	181	16,5	90	1000	28	ZE-MSK150D
200	204	63	149	127	579	609	18	312	148	190	350	234	21	122	1400	56	ZE-MSK200D

3-Achsen-Schraubstöcke 3-axes machine vices

Typ MSK3 Type MSK3

- 3-fach verstellbar
- 360° drehbar
- 0-90° vertikal verstellbar
- ± 45° schwenkbar
- Backen gehärtet und geschliffen
- adjustable in 3 ways
- 360° rotatable
- 0-90° vertically adjustable
- ± 45° tiltable
- jaws hardened and ground

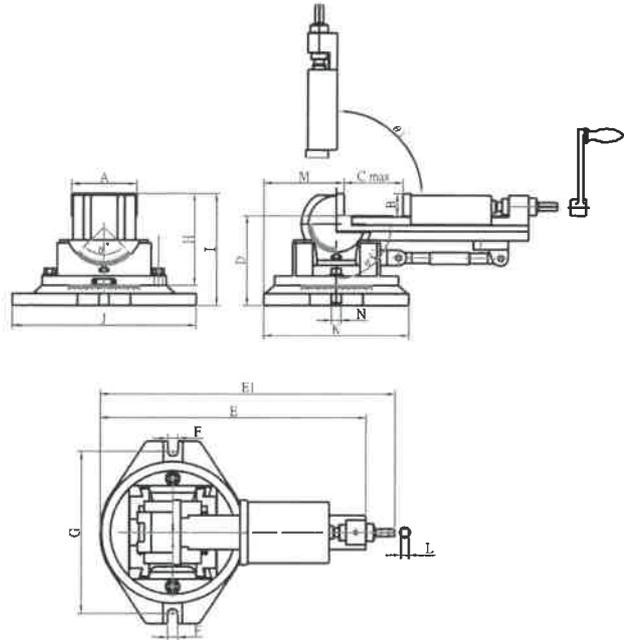

Typ / Type	A mm	B mm	Cmax mm	D mm	E mm	E1 mm	F mm	G mm	H mm	I mm	J mm	K mm	L mm	M mm	N mm	Max. Spann- kraft / Clamping force daN	kg	Art.-Nr. / Order no.
80	80	31	85	126	335	370	15	210	127	157	240	185	10	95	16	800	17	ZE-MSK3-080
110	110	38	115	152	448	497	17	276	157	190	311	245	13	135	16	1000	33	ZE-MSK3-110
135	135	40	150	170	530	580	17	310	173	210	358	271	13	140	16	1600	50	ZE-MSK3-135

Bohrmaschinenschraubstöcke Drilling machine vices



Bohrmaschinen-Schraubstock Typ MSP Drilling machine vice type MSP

- Körper aus Guss
- Stahlbacken mit vertikalem und horizontalem Prisma
- cast iron body
- steel jaws with vertical and horizontal prism

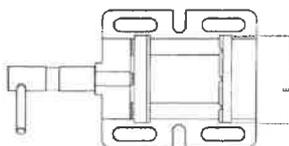
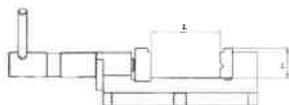

Typ / Type	Backenbreite / Jaw width mm	Spannweite / Max. opening mm	Backenhöhe / Jaw height mm	kg	Art.-Nr. / Order no.
MSP 80	85	65	29	4	OT-206085
MSP 100	100	85	33	5	OT-206100
MSP 120	120	110	33	8	OT-206120

Werkbankschraubstöcke Table vices

Werkbankschraubstöcke Typ WBS Table vices type WBS



- sehr stabile Konstruktion
- Backen aus Hochqualitätsstahl, gehärtet auf 54 HRC ± 5
- große Ambossfläche
- integrierte Drehplatte ± 35° mit Positionsschrauben
- Typ T: mit Backen für Rundmaterial
- sturdy design
- jaws made from high-quality steel, hardened to 54 HRC ± 5
- large anvil
- integrated swivel base ± 35° with position screws
- type T: with pipe jaws



Typ T
Type T

Typ / Type	Backenbreite / Width of jaws mm	Spannweite / Clamping range mm	Spannkraft / Clamping force daN	kg	Art.-Nr. / Order no.
63	63	55	3500	4	14-WBS-063
80	80	70	3500	6	14-WBS-080
100	100	105	3500	12,5	14-WBS-100
125	125	115	3500	20	14-WBS-125
125T *	125	115	3500	20	14-WBS-125T
150	150	125	3500	30	14-WBS-150
150T *	150	125	3500	30	14-WBS-150T

* mit Backen für Rundmaterial
* with pipe jaws



- Schraubstock für große Belastungen
- auf Drehplatte, 360° drehbar
- Ambossfläche 70 x 150 mm
- Backen aus Hochqualitätsstahl, gehärtet auf 52 - 54 HRC
- Typ T: mit Backen für Rundmaterial
- heavy-duty vice
- swivel base, 360° rotatable
- large anvil 70x150 mm
- jaws made from high-quality steel, hardened to 52 - 54 HRC
- type T: with pipe jaws



Typ T
Type T

Typ / Type	Backenbreite / Width of jaws mm	Spannweite / Clamping range mm	Spannkraft / Clamping force daN	kg	Art.-Nr. / Order no.
200	200	200	5500	40	14-WBS-200
200T	200	200	5500	40	14-WBS-200T
250 *	250	200	5500	45	14-WBS-250
250T *	250	200	5500	45	14-WBS-250T

* mit Backen für Rundmaterial
* with pipe jaws

Teleskophalter für Werkbank-Schraubstöcke Telescopic holder for table vices



- Teleskophalter passend zu Typ WBS 100, 125, 150
- ermöglicht eine Höhenverstellung des Schraubstockes
- Einstellungsbereich: 0 - 200 mm
- telescopic holder suitable for types WBS 100, 125, 150
- for height adjustment of vices
- range of adjustment: 0 - 200 mm

Typ / Type	Höhenverstellung / Range of adjustment mm	kg	Art.-Nr. / Order no.
TP200	0-200	8,6	14-TP200

Zentrischspanner Typ ZSM2

Self-centering vices type ZSM2

Zentrischspanner Typ ZSM2

Self-centering vice type ZSM2

- Für 4/5-Achs-Bearbeitung
- Wiederholgenauigkeit: 0,01 mm
- mit Niederzugeffekt
- for 4/5-axes machining
- repeatability: 0,01 mm
- with pull-down mechanism

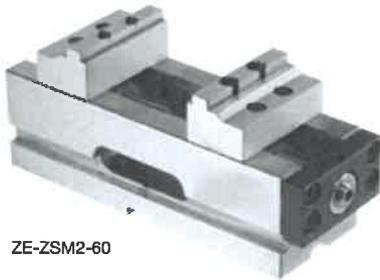

ZE-ZSM2-60

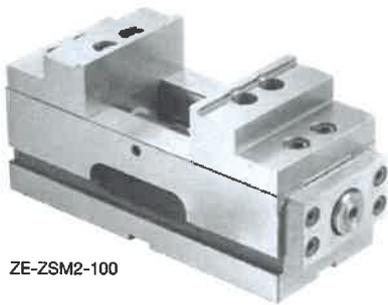
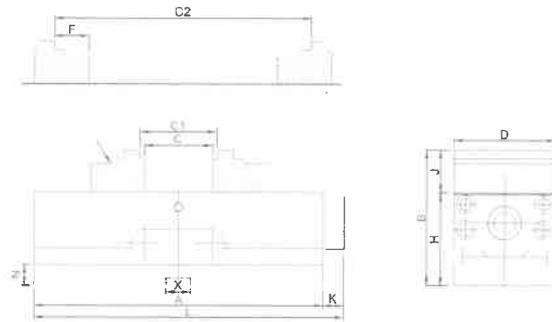

ZE-ZSM2-100

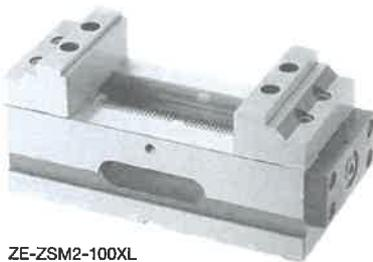
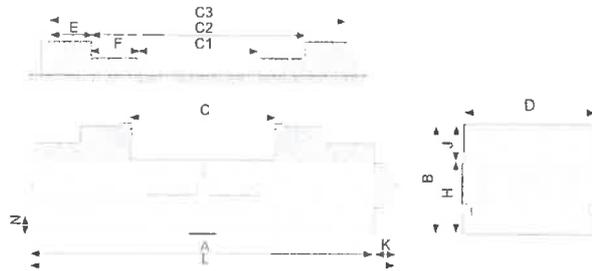

ZE-ZSM2-100XL

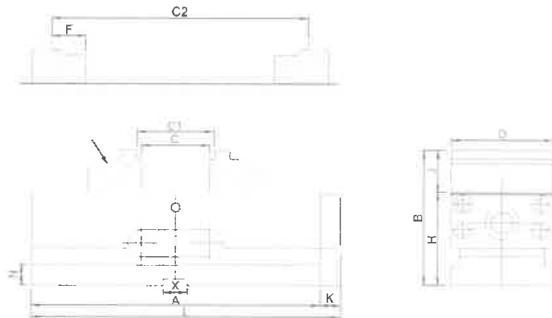

D mm	A mm	B mm	C offen / open mm	C1	C2	C3	F mm	H mm	J mm	K mm	N mm	X mm	L mm	Art.-Nr. / Order no.
Spannweite / Clamping range														
60	170	80	100	112	45-140	-	20	55	25	15	14	14	185	ZE-ZSM2-60
100	240	120	90	90	70-160	134-222	35	80	40	20	22	18	260	ZE-ZSM2-100
100	240	120	130	140	62-190	-	30	80	40	16	21	16	256	ZE-ZSM2-100XL

Inkl. 4 Spannpratzen und Schlüssel
Incl. 4 clamping brackets and key

5-Achsen-Zentrischspanner, Typ SR5 5-axes self-centering vices, type SR5

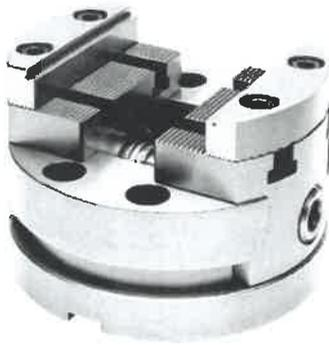

Zentrischspanner, Typ SR5 Self-centering vices, type SR5

- für 5-Achs-Bearbeitung
- runder Körper, für weniger Störkon-
turen und geringeren Platzbedarf
- ideal zum Einsatz auf Rundtischen,
Teilapparaten etc.
- suitable for 5-axis machining
- round body for less interference and
less requirement space
- ideal for use with indexing spacers,
rotary tables etc.

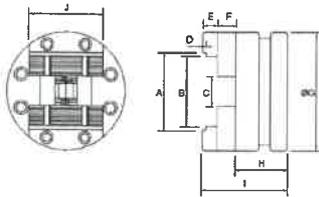

Typ / Type	A mm	B mm	C mm	D mm	E mm	F mm	G mm	H mm	I mm	J mm	Art.-Nr. / Order no.
100	105	95	40	5	20	25	160	70	115	100	14-SR5-100
130	135	125	50	5	20	25	210	80	125	130	14-SR5-130
160	165	155	60	5	25	25	250	90	140	160	14-SR5-160

Schleifschraubstöcke Tool maker vices



TMV-A, mit Schnellverstellung TMV-A, with quick adjustment

- aus Legierungsstahl, wärmebehandelt, gehärtet 58 HRC und feingeschliffen
- geeignet zum Einsatz auf Fräs- und Schleifmaschinen
- auch als Kontrollschraubstock verwendbar
- Parallelität: 0,005 mm / 100 mm
- Rechtwinkligkeit: 0,005 mm / 100 mm
- made from heat treated alloy steel, subzero treatment for stress relief against distortion, hardened 58 HRC and finished by grinding
- suitable for milling and grinding machines
- also suitable as reference for inspection
- parallelism: 0,005 mm / 100 mm
- squareness: 0,005 mm / 100 mm

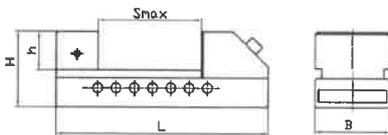

Typ / Type	B mm	H mm	S mm	L mm	kg	Art.-Nr. / Order no.
A50	50	25	65	140	2	14-TMV-A50
A63	63	32	85	175	3	14-TMV-A63
A73	73	35	100	190	4	14-TMV-A73
A100	100	45	125	245	10	14-TMV-A100
A125	125	50	160	285	18	14-TMV-A125
A150	150	50	200	330	21	14-TMV-A150

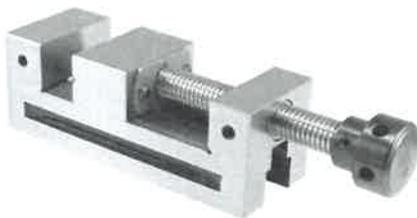

TMV-B, mit Gewindespindel TMV-B, screw type

Typ / Type	B mm	H mm	S mm	L mm	kg	Art.-Nr. / Order no.
B50	50	25	65	155	2	14-TMV-B50
B73	73	35	100	210	3,5	14-TMV-B73
B100	100	45	125	260	5	14-TMV-B100

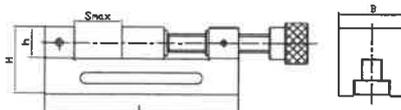

Sinus-Schraubstöcke

Sine vices



TMV-SA, mit Schnellverstellung

TMV-SA, with quick adjustment

- genaue Winkeleinstellung (0-45°) durch Endmaße
 - sichere Fixierung des Schraubstocks in jeder Winkeleinstellung
 - Parallelität: 0,005 mm / 100 mm
 - Rechtwinkligkeit: 0,005 mm / 100 mm
- accurate angle setting (0-45°) by gauge blocks
 - safe fixation in any angular position
 - parallelism: 0,005 mm / 100 mm
 - squareness: 0,005 mm / 100 mm



Typ / Type	B mm	H mm	H1 mm	S mm	L mm	L1 mm	kg	Art.-Nr. / Order no.
SA63	63	32	92	85	175	100	5	14-TMV-SA63
SA73	73	35	104	100	190	100	9	14-TMV-SA73
SA88	88	40	122	125	235	100	11	14-TMV-SA88



TMV-SB, mit Gewindespindel

TMV-SB, screw type

- Winkeleinstellung (0-45°)
- angle setting (0-45°)

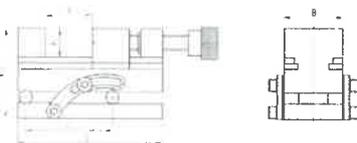

Typ / Type	B mm	H mm	H1 mm	S mm	L mm	L1 mm	kg	Art.-Nr. / Order no.
SB63	63	32	94	85	175	100	5	14-TMV-SB63
SB73	73	35	111	90	190	100	9	14-TMV-SB73
SB100	100	45	139	125	245	100	17	14-TMV-SB100



TMV-SB2, mit Gradeinteilungen

TMV-SB2, with scales

- in 2 Ebenen verstellbar
 - 360° drehbar, 60° schwenkbar
 - Nonius
 - Parallelität: 0,005 mm / 100 mm
 - Rechtwinkligkeit: 0,005 mm / 100 mm
- adjustable in 2 axes
 - 360° rotatable, 60° tiltable
 - vernier
 - parallelism: 0,005 mm / 100 mm
 - squareness: 0,005 mm / 100 mm

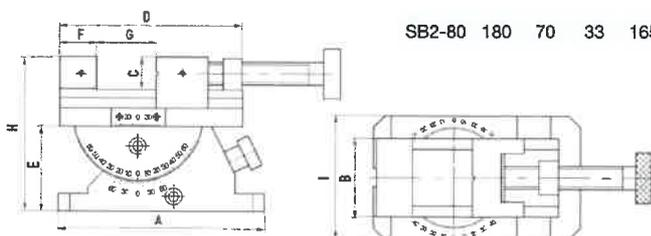

Typ / Type	A mm	B mm	C mm	D mm	E mm	F mm	G mm	H mm	I mm	kg	Art.-Nr. / Order no.
SB2-80	180	70	33	165	73	30	0-85	139	130	14	14-TMV-SB2-80

Schleif- und Erodier-Schraubstöcke

Grinding and erosion vices

Typ SES, rostfrei

Type SES, noncorrosive



Abbildung 1 / figure 1



Abbildung 2 / figure 2

- geeignet für den Einsatz auf Erodier- und Schleifmaschinen für die präzise Bearbeitung von Werkstücken
 - Material: nichtrostender Chromstahl 50 - 55 HRC
 - Parallelität: 0,003 mm / 100 mm
 - Rechtwinkligkeit: 0,003 mm / 100 mm
- suitable for milling, grinding and high precision operations
 - material: stainless steel 50 - 55 HRC
 - parallelism: 0,003 mm / 100 mm
 - squareness: 0,003 mm / 100 mm

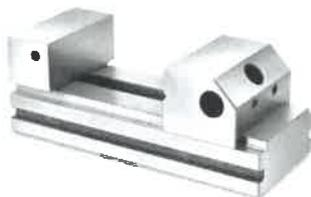
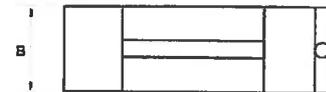
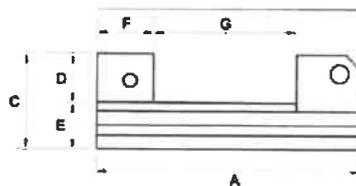

Typ / Type	Abbildung / figure	A mm	B mm	C mm	D mm	E mm	F mm	G mm	kg	Art.-Nr. / Order no.
SES-25 Mini*	1	65	25	30	10	-	20	0-19	0,3	14-SES-25
SES-50	2	140	50	53	25	28	25	0-75	1,8	14-SES-50
SES-72	2	180	72	62	30	32	35	0-100	3,8	14-SES-72

* mit Stufenbacke / with stepped jaw

Erodier-Schraubstöcke

Erosion vices

Typ SESP, rostfrei

Type SESP, noncorrosive

- hochgenauer Schraubstock, geeignet zum Einsatz auf Erodiermaschinen
- hohe Spannkraft garantieren stabile Positionierung der Werkstücke auch bei hohem Kühlwasserdruck
- Material: nichtrostender Chromstahl 54 HRC ± 2
- Parallelität: 0,002 mm / 100 mm
- Rechtwinkligkeit: 0,002 mm / 100 mm
- high precision vise, suitable for use on eroding machines
- high clamping forces guarantee stable positioning of work piece even at high coolant pressure
- material: stainless steel, hardened treatment up to 54 HRC ± 2
- parallelism: 0,002 mm / 100 mm
- squareness: 0,002 mm / 100 mm

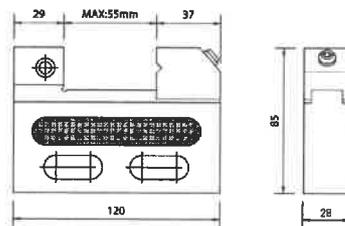
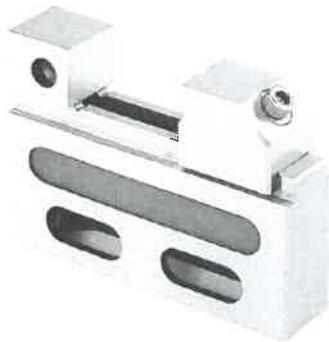

Spannweite / Opening mm	kg	Art.-Nr. / Order no.
55	1	14-SESP-28/50

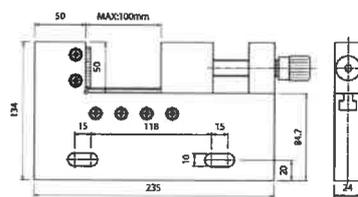
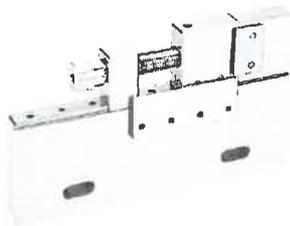

Spannweite / Opening mm	kg	Art.-Nr. / Order no.
100	5	14-SESP-24/100

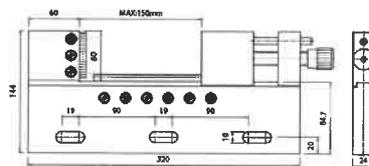
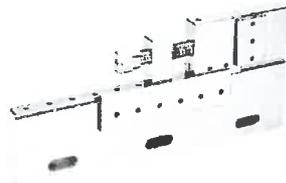

Spannweite / Opening mm	kg	Art.-Nr. / Order no.
150	7	14-SESP-24/150

- in aufgespanntem Zustand justierbar in 3 Achsen
- nichtrostender Chromstahl, 45 - 55 HRC
- Parallelität: 0,003 mm / 100 mm
- Rechtwinkligkeit: 0,005 mm / 100 mm
- adjustable in 3 axes
- material: stainless steel, 45 - 55 HRC
- parallelism: 0,003 mm / 100 mm
- squareness: 0,005 mm / 100 mm

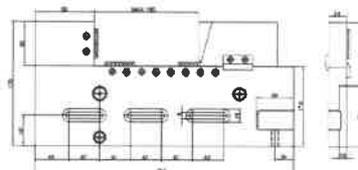
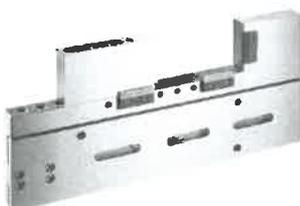

Spannweite / Opening mm	kg	Art.-Nr. / Order no.
160	8	14-SESP-24/160

Erodier-Schraubstöcke

Erosion vices

- zum Spannen von Elektroden auf Erodiermaschinen
- Material: nichtrostender Chromstahl HRC 48 - 55
- Parallelität: 0,003 mm / 100 mm
- Rechwinkligkeit: 0,005 mm / 100 mm
- for clamping of electrodes on eroding machines
- material: stainless steel, hardened treatment up to HRC 48 - 55
- parallelism: 0,003 mm / 100 mm
- squareness: 0,005 mm / 100 mm

Typ REHS, mit Schnellverstellung

Type REHS, with quick adjustment

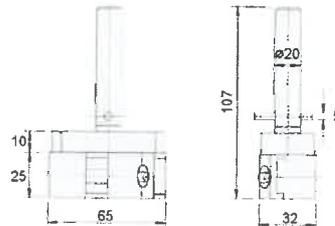

Backenbreite / Width of jaws mm	Spannweite / Clamping range mm	kg	Art.-Nr. / Order no.
25	0-20	1	14-REHS-20

Typ REHG 20, mit Gewindespindel

Type REHG 20, screw type

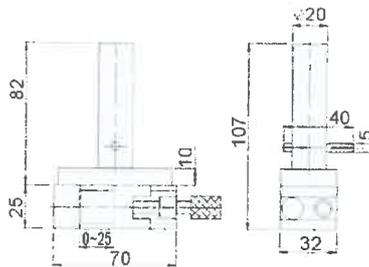

Backenbreite / Width of jaws mm	Spannweite / Clamping range mm	kg	Art.-Nr. / Order no.
25	0-25	1	14-REHG-20

Typ REHG 50, mit Gewindespindel

Type REHG 50, screw type

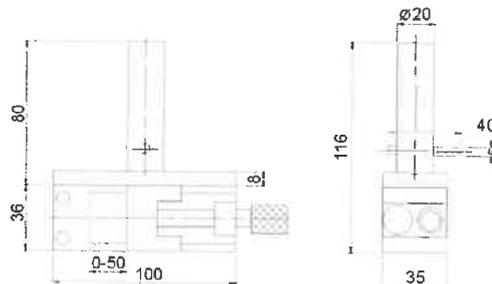

Backenbreite / Width of jaws mm	Spannweite / Clamping range mm	kg	Art.-Nr. / Order no.
36	0-50	1,5	14-REHG-50



Zentrisch spannende Doppelschraubstöcke Self-centering double vices

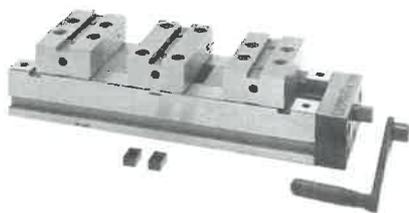

Typ EDMA.99, mechanisch Type EDMA.99, mechanical

Einsatz horizontal oder seitlich.
Hochbelastbare Trapezzspindel.

Used on level ground or on side.
Heavy-duty trapezoidal spindle.

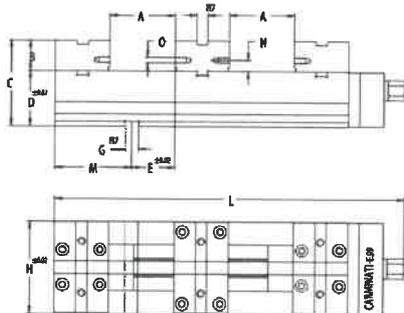

Material: Legierter Stahl,
gehärtet und
geschliffen

Material: Hardened alloy
steel, precision
ground

Spannkraft: Typ 100: 1,8 t
Typ 125: 2,5 t
Typ 150: 3,5 t

Clamping force: Type 100: 1,8 t
Type 125: 2,5 t
Type 150: 3,5 t

Typ / Type	A mm	B mm	C mm	D mm	E mm	F mm	G mm	H mm	L mm	M mm	N mm	O mm	kg	Art.-Nr. / Order no.
100	80	33	93	60	46	12	14	100	374	82	12	M6	20	▶ 14-EDMA99-100
125	96	42	112	70	61	16	16	125	474	107	22	M6	38	▶ 14-EDMA99-125
150	145	52	132	80	61	16	16	150	584	162	22	M8	61	▶ 14-EDMA99-150

Präzisionsschraubstöcke mit Niederzugbacken Precision vices with pull-down jaws



Typ SP.81, mechanisch - modulares System Type SP.81, mechanical - modular system

Eigenschaften:

- Niederzugbacken drücken das Werkstück sicher nach unten
- beim Lösen gehen die Backen in die Ausgangsstellung zurück
- große Spannweite, schnelle Vor-einstellung über Kugelrastbolzen
- alle Teile sind gehärtet und geschliffen und ergeben höchste Präzision
- Lieferung erfolgt ohne Drehplatte

Main features:

- pull-down jaws which clamp the work piece on the plate under any conditions
- jaw return control
- wide opening and quick positioning for special machining
- all parts are hardened and ground
- Supplied without swivel plate

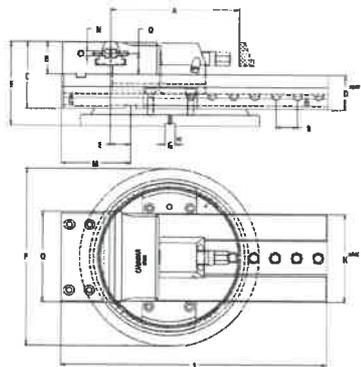

Material: Legierter Stahl,
gehärtet und
geschliffen

Material: Hardened alloy
steel, precision
ground

Spannkraft: Typ 100: 2,5 t
Typ 125: 3,5 t
Typ 150: 4 t
Typ 200: 5 t

Clamping force: Type 100: 2,5 t
Type 125: 3,5 t
Type 150: 4 t
Type 200: 5 t

Typ / Type	A mm	B mm	C mm	D mm	E mm	F mm	G mm	H mm	L mm	M mm	N mm	O mm	P mm	Q mm	R mm	kg	Art.-Nr. / Order no.
100	120	39,5	79,5	40	1,5	102,5	14	95	301	61	M6	25,5	205	100	20	18	▶ 14-SP81-100
125	159	46	89	43	11,5	116	14	120	352	81	M6	30	238	125	27	28	▶ 14-SP81-125
150	210	53	110	57	33,5	138	16	145	435	112	M8	34	293	150	35	49	▶ 14-SP81-150
200	320	67	134	67	44	168	16	195	596	142	M8	43,5	343	200	40	97	▶ 14-SP81-200

Präzisionsschraubstöcke mit Niederzugbacken

Precision vices with pull-down jaws

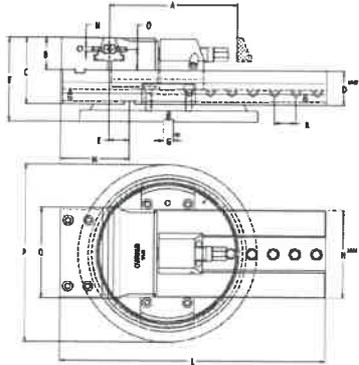

Typ ISP.81, mechanisch-hydraulisch - modulares System

Type ISP.81, mechanical-hydraulic - modular system

Präzisions-Schraubstock. Ausführung wie Grundmodell SP.81, jedoch mit eingebauter Hydraulikspindel und mechanischem Antrieb. Lieferung erfolgt ohne Drehplatte.

Precision vice. Design identical to basic model SP.81, however with integrated hydraulic/mechanic spindle. Supplied without swivel plate.

Material: Legierter Stahl, gehärtet und geschliffen

Material: Hardened alloy steel, precision ground

Spannkraft: Typ 100: 2 t
Typ 125: 3 t
Typ 150: 4 t
Typ 200: 5 t

Clamping force: Type 100: 2 t
Type 125: 3 t
Type 150: 4 t
Type 200: 5 t

Typ / Type	A mm	B mm	C mm	D mm	E mm	F mm	G mm	H mm	L mm	M mm	N mm	O mm	P mm	Q mm	R mm	kg	Art.-Nr. / Order no.
100	120	39,5	79,5	40	1,5	102,5	14	95	301	61	M6	25,5	205	100	20	19	▶ 14-ISP81-100
125	159	46	89	43	11,5	116	14	120	352	81	M6	30	238	125	27	29	▶ 14-ISP81-125
150	210	53	110	57	33,5	138	16	145	435	112	M8	34	293	150	35	51	▶ 14-ISP81-150
200	320	67	134	67	44	168	16	195	596	142	M8	43,5	343	200	40	99	▶ 14-ISP81-200

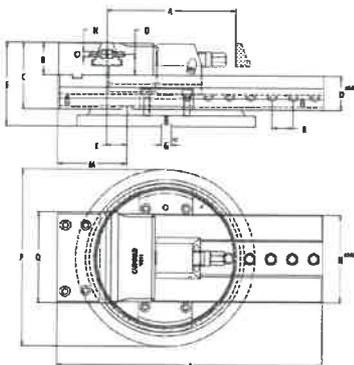
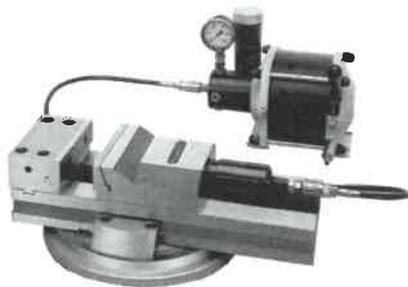

Typ OSP.81, pneumatisch-hydraulisch - modulares System

Type OSP.81, pneumatical-hydraulic - modular system

Präzisions-Schraubstock. Ausführung wie Grundmodell SP.81, jedoch mit eingebautem Hydraulikzylinder in Verbindung mit einem pneumatisch-hydraulischen Druckübersetzer; dadurch besonders geeignet für Serienfertigung. Die bewegliche Backe lässt sich leicht voreinstellen. Lieferung erfolgt inklusive Druckübersetzer, ohne Drehplatte.

Precision vice. Design identical to basic model SP.81, however with integrated hydraulic cylinder incl. pneumatic-hydraulic pressure multiplier. Especially suitable for series manufacture. The moveable jaw can easily be preadjusted. Supplied with pressure multiplier, without swivel plate.

Material: Legierter Stahl, gehärtet und geschliffen

Material: Hardened alloy steel, precision ground

Hub: 6 mm

Stroke: 6 mm

Spannkraft: Typ 125: 2,5 t
(bei 8 bar)
Typ 150: 4,5 t
Typ 200: 5,5 t

Clamping force: Type 125: 2,5 t
(at 8 bar)
Type 150: 4,5 t
Type 200: 5,5 t

Typ / Type	A mm	B mm	C mm	D mm	E mm	F mm	G mm	H mm	L mm	M mm	N mm	O mm	P mm	Q mm	R mm	kg	Art.-Nr. / Order no.
125	159	46	89	43	11,5	116	14	120	352	81	M6	30	238	125	27	29	▶ 14-OSP81-125
150	210	53	110	57	33,5	138	16	145	435	112	M8	34	293	150	35	51	▶ 14-OSP81-150
200	320	67	134	67	44	168	16	195	596	142	M8	43,5	343	200	40	99	▶ 14-OSP81-200

Lieferbar auch mit verlängertem Bett auf Anfrage
Longer version available upon request



Universal-Werkstückanschlag Universal stop-dog

Universal-Werkstückanschlag Universal stop-dog



- Universal-Werkstückanschlag aus zweifarbig eloxiertem Aluminium für Bohr- und Fräsmaschinen
- durch die zwei Gelenkpfannen und den 360° drehbaren Kopf ist jede Einstell-Lage möglich
- inkl. Nutenstein (für 16, 18 und 20 mm T-Nuten), Anschlagstange und Inbus-schlüssel
- universal two-coloured work piece stop, made from anodized aluminium for boring and milling machines
- two cranks and a knob (360° pivotable) allow any setting angle
- incl. t-nut (for 16, 18 and 20 mm), stop rod and hexagon wrench

Höhe Anschlagst. / Height of stop rod mm	Gesamthöhe / Total height mm	Anschlagst.-Ø / Stop rod dia. mm	Art.-Nr. / Order no.
155	215	8	09-AMS-160BH

Universal Aufsatz-Prismenbacken für Schraubstöcke Universal prism jaws for vices

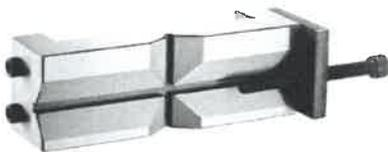

Universal Aufsatz-Prismenbacken mit Werkstückanschlag Universal prism jaws with work stop

- geeignet für alle gängigen Schraubstöcke
- leicht und schnell montierbar
- suitable for all kinds of vices
- easy mounting and handling

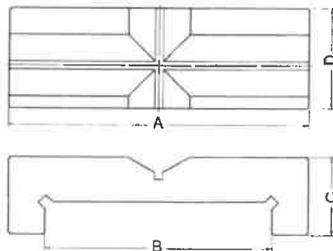

Für Backen- breite / For jaw width mm	A mm	B mm	C mm	D mm	kg	Art.-Nr. / Order no.
100-110	145	110	38	49	1,6	14-APB-100/110
125-140	175	140	39	49	1,7	14-APB-125/140
150-160	190	160	40	53	2	14-APB-150/160
200-210	245	210	42	76	4,2	14-APB-200/210

Preis pro Stück / Price per piece