

Zubehör

Accessories



■ Inhalt:

- 1 | **Zubehör für Drehfutter und Planscheiben**
 - | Sicherheits- Dreh- und Schleifmitnehmer
 - | Hohlspindelanschlag
- 2 | **Zubehör für Schraubstöcke**
 - | Passsteine
 - | Universal-Werkstückanschlag
 - | Universal-Werkstückanschlag mit Magnet
- 3 | **Zubehör für Steilkegelaufnahmen**
 - | Kegelwischer
 - | Fräsdornringe
 - | Schlüssel
 - | Fräseranzugsschrauben
 - | Austreiblappen
 - | Überwurfmuttern
 - | Mitnehmerringe
 - | Passfedern
 - | Spanschrauben für Weldon Futter
 - | Austreiber
 - | Schraubquerkeile
 - | Kühlmittelröhrchen
 - | Werkzeug-Regale
 - | Werkzeugwagen
 - | Montagehilfen

■ Content:

- | **Accessories for lathe and independent chucks**
 - | Safety driving rings
 - | Hollow spindle stops
- | **Accessories for vices**
 - | Tee nuts
 - | Stop dog
 - | Universal work piece stop with magnet
- | **Accessories for SK-tooling**
 - | Taper cleaners
 - | Spacing collars
 - | Spanners
 - | Cross retaining screws
 - | Tangs
 - | Clamping nuts
 - | Clutch drive rings
 - | Feather keys
 - | Clamping screws for Weldon chucks
 - | Ejectors
 - | Driving tenons
 - | Coolant tubes
 - | Tool racks
 - | Tooling trolleys
 - | Assembly supports

Sicherheits- Dreh- und Schleifmitnehmer Safety drive rings



- Nachfolger des nicht mehr zulässigen Drehherzes
- Keine Unfallgefahr, da keine hervorstehenden Teile
- Eingestellter Spanndurchmesser wird beibehalten
- Zweiteilig - kann auch bei eingespanntem Werkstück angebracht werden
- *No risk of injuries since free from protruding elements*
- *Adjusted clamping diameter is maintained*
- *Split design to allow mounting while work-piece is clamped*

Größe / Size	Spannbereich / Clamping range mm	Art.-Nr. / Order no.
1	10-40	00-SM-1
2	40-70	00-SM-2
3	70-100	00-SM-3
4	100-150	00-SM-4
5	150-200	00-SM-5
6	200-250	00-SM-6

Passteine, Paar Tee nuts, set of 2 pieces

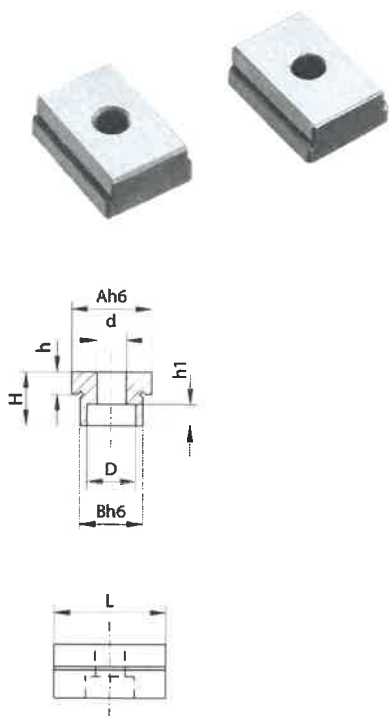

A mm	B mm	L mm	H mm	h mm	h1 mm	D mm	d mm	Art.-Nr. / Order no.
12	12	25	10	4,8	5,7	10	6	14-12-12
	14			0				14-14-14
14	18	25	10	4,8	5,7	10	6	14-14-18
	20			4,8				14-14-20
	22			4,8				14-14-22
16	12	25	10	4,8	5,7	10	6	14-16-12
	14			4,8				14-16-14
	16			0				14-16-16
	18			4,8				14-16-18
	20			4,8				14-16-20
	22			4,8				14-16-22
	24			4,8				14-16-24
	28			4,8				14-16-28
18	12	25	10	4,8	5,7	10	6	14-18-12
	14			4,8				14-18-14
	16			4,8				14-18-16
	18			0				14-18-18
	20			4,8				14-18-20
	22			4,8				14-18-22
20	12	25	10	4,8	5,7	10	6	14-20-12
	14			4,8				14-20-14
	16			4,8				14-20-16
	18			4,8				14-20-18
	20			0				14-20-20
	22			4,8				14-20-22
22	14	25	10	4,8	5,7	10	6	14-22-14
	16			4,8				14-22-16
	18			4,8				14-22-18
	20			4,8				14-22-20
	22			4,8				14-22-22

Universal-Werkstückanschlag Universal stop-dog

Preis pro Paar / Price per set



- Universal-Werkstückanschlag aus zweifarbig eloxiertem Aluminium für Bohr- und Fräsmaschinen
- durch die zwei Gelenkpfannen und den 360° drehbaren Kopf ist jede Einstell-Lage möglich
- inkl. Nutenstein (für 16, 18 und 20 mm T-Nuten), Anschlagstange und Inbus-schlüssel
- universal two-coloured work piece stop made from anodized aluminium for boring and milling machines
- two cranks and a knob (360° pivotable) allow any setting angle
- incl. t-nut (for 16, 18 and 20 mm), stop rod and hexagon wrench

Höhe Anschlagst. / Height of stop rod mm	Gesamthöhe / Total height mm	Anschlagst.-Ø / Stop rod dia. mm	Art.-Nr. / Order no.
155	215	8	09-AMS-160BH

Universal-Werkstückanschlag mit Magnet Universal work piece stop with magnet



- passend für alle Schraubstöcke
- keine Gewindebohrungen nötig
- suitable for all types of vices
- no threads required

Gesamthöhe / Total height mm	Länge der Anschlagstange / Length of stop rod mm	Anschlagst.-Ø / Stop rod-Ø mm	Art.-Nr. / Order no.
100	125	6	09-WAM



Kegelwischer Taper cleaners



SK

- Material: Holz

- material: wood

SK	Art.-Nr. / Order no.
30	09-76200030
40	09-76200040
45	09-76200045
50	09-76200050
60	09-76200060



MK / MT

- Material: Holz

- material: wood

MK / MT	Art.-Nr. / Order no.
1	09-76200001
2	09-76200002
3	09-76200003
4	09-76200004
5	09-76200005
6	09-76200006



HSK

- Material: Kunststoff
- passend für Form A / C / E

- material: plastic
- suitable for form A / C / E

HSK	Art.-Nr. / Order no.
32	09-76205032
40	09-76205040
50	09-76205050
63	09-76205063
80	09-76205080
100	09-762050100



ER

- Material: Holz

- material: wood

ER	Art.-Nr. / Order no.
16	09-76202016
20	09-76202020
25	09-76202025
32	09-76202032
40	09-76202040



OZ

- Material: Holz

- material: wood

OZ	Art.-Nr. / Order no.
OZ 6 (400E)	09-76203006
OZ 8 (401E)	09-76203008
OZ 16 (415E / 410E)	09-76203016
OZ 25 (462E / 444E)	09-76203025
OZ 32 (467E / 450E)	09-76203032



Fräsdornringe DIN 2084 A Spacing collars DIN 2084 A



Form A

Aus federhartem Spezialstahl gestanz
und entgratet.

From punched spring steel, deburred
edges.

Bohr-Ø / Bore-Ø	16	22	27	32	40	50	60
Außen-Ø / External-Ø	25	33	39	45	54	67	83

Stärke /
Thickness
mm

0,03
0,04
0,05
0,10
0,20
0,30
0,40
0,50
0,60
1,00

Weitere Größen auf Anfrage
*Further sizes available upon
request*

Beispiel / Ordering example: 27 x 0,03 = 09-2084A27003

09-2084AØ

Abgabe nur in VE à 10 Stück. Der Preis versteht sich pro Stück.
Only available in sets of 10 pieces. Price is per piece.

Fräsdornringe DIN 2084 B Spacing collars DIN 2084 B



Form B

Aus Stahl gedreht, gehärtet, planparallel
geschliffen und geläppt.

Turned from steel, hardened, ground and
lapped.

Bohr-Ø / Bore-Ø	13	16	22	27	32	40	50	60
Außen-Ø / External-Ø	22	27	34	41	47	55	69	83

Stärke /
Thickness
mm

1
2
3
4
5
6
10
20
30
60
100

Weitere Größen und Endringe
auf Anfrage
Further sizes and end rings
available upon request

Beispiel / Ordering example: 16 x 1 = 09-2084B161

09-2084BØ

Preis versteht sich für 1 Stück



Fräsdornringe DIN 2084 B Spacing collars DIN 2084 B

Fräsdornringe-Sortiment Spacing collar sets



- Lieferung erfolgt in Kunststofftasche

- delivered in plastic case

Sortiment / Set	Bohrung / Bore mm	Inhalt / Contents	Art.-Nr. / Order no.
1	16	60	09-2084A16S1
1	22	60	09-2084A22S1
1	27	60	09-2084A27S1
1	32	60	09-2084A32S1
1	40	60	09-2084A40S1
2	16	35	09-2084A16S2
2	22	35	09-2084A22S2
2	27	35	09-2084A27S2
2	32	35	09-2084A32S2
2	40	35	09-2084A40S2

Sortiment / Set	0,03	0,04	0,05	0,1	0,2	0,3	0,5	0,6	1,0	1,5
1	10	10	10	10	5	5	4	3	2	1
2	5	5	5	6	3	3	3	2	2	1

Schlüssel Spanners



Sicherheitsschlüssel ER Mini Safety-spanners ER Mini

ER	Art.-Nr. / Order no.
ER 8 M	09-SCH-ER8M
ER 11 M	09-SCH-ER11M
ER 16 M	09-SCH-ER16M
ER 20 M	09-SCH-ER20M
ER 25 M	09-SCH-ER25M



Sicherheitsschlüssel ER Safety-spanners ER

ER	Art.-Nr. / Order no.
ER 16	09-SCH-ER16
ER 20	09-SCH-ER20
ER 25	09-SCH-ER25
ER 32	09-SCH-ER32
ER 40	09-SCH-ER40
ER 50	09-SCH-ER50



Hakenschlüssel OZ Hook wrenches OZ

Für SZ / For collet	Ø mm	OZ	Art.-Nr. / Order no.
415 E	43	OZ 16	09-SCH-OZ16
462 E	60	OZ 25	09-SCH-OZ25
467 E	72	OZ 32	09-SCH-OZ32
468 E	82	OZ 40	09-SCH-OZ40

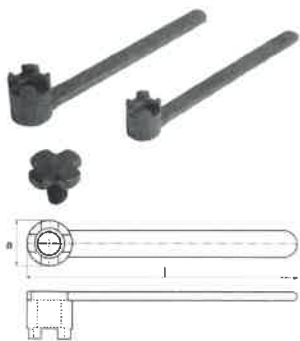

Schlüssel für Fräseranzugsschrauben DIN 6368 Spanners for cross screws DIN 6368

Für Ø / For Ø	Schraube / Screw	l mm	Art.-Nr. / Order no.
13	M6	160	09-SCH-KD13
16	M8	180	09-SCH-KD16
22	M10	200	09-SCH-KD22
27	M12	225	09-SCH-KD27
32	M16	250	09-SCH-KD32
40	M20	280	09-SCH-KD40
50	M24	315	09-SCH-KD50

Fräseranzugsschrauben Cross retaining screws

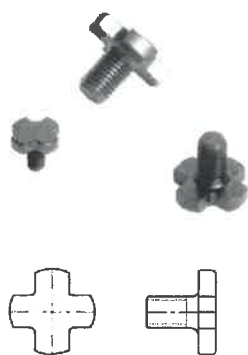

Für Fräsdorne DIN 6367 For shell end mill holders DIN 6367

Fräsdorn / Arbor	Gewinde / Thread	Art.-Nr. / Order no.
13	M6	09-VTC-M6
16	M8	09-VTC-M8
22	M10	09-VTC-M10
27	M12	09-VTC-M12
32	M16	09-VTC-M16
40	M20	09-VTC-M20

Für Fräsdorne DIN 6367 mit innerer Kühlmittelzufuhr For shell end mill holders DIN 6367 with IC



Fräsdorn / Arbor	Gewinde / Thread	Art.-Nr. / Order no.
16	M8	09-VTCIK-M8
22	M10	09-VTCIK-M10
27	M12	09-VTCIK-M12
32	M16	09-VTCIK-M16
40	M20	09-VTCIK-M20

Austreibblappen Tangs



Einschraubbare Austreibblappen für Morsekegel Removable tangs for morse taper shanks

MK / MT	Gewinde / Thread	Art.-Nr. / Order no.
1	M6	09-ATL-MK1
2	M10	09-ATL-MK2
3	M12	09-ATL-MK3
4	M16	09-ATL-MK4
5	M20	09-ATL-MK5

Überwurfmuttern OZ Standard clamping nuts OZ



Kugelgelagert With roller-bearing

Für SZ / For collet	d5	l1 mm	Art.-Nr. / Order no.
OZ 16 (415E)	M33 x 1,5	24	09-GOC-16
OZ 20 (4541E)	M42 x 2	28	09-GOC-20
OZ 25 (462E)	M48 x 2	30	09-GOC-25
OZ 32 (467E)	M60 x 2,5	33,5	09-GOC-32
OZ 40 (468E)	M68 x 2,5	37	09-GOC-40

Überwurfmutter ER Clamping nuts ER

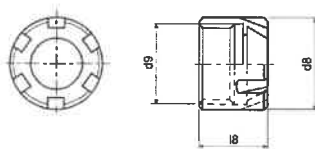

Mini Mini

Für SZ / For collet	d9 mm	d8 mm	L8 mm	Art.-Nr. / Order no.
ER 8	M10 x 0,75	12	10,8	09-G-8M
ER 11	M13 x 0,75	16	12	09-G-11M
ER 16	M19 x 1	22	18	09-G-16M
ER 20	M24 x 1	28	19	09-G-20M
ER 25	M30 x 1	35	20	09-G-25M

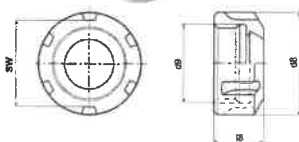

Standard Standard

Für SZ / For collet	d9 mm	d8 mm	L8 mm	SW	Art.-Nr. / Order no.
ER 16	M22 x 1,5	32	17	27	09-UM-ER16
ER 20	M25 x 1,5	35	18,5	30	09-UM-ER20
ER 25	M32 x 1,5	42	20	37	09-UM-ER25
ER 32	M40 x 1,5	50	22,5	45	09-UM-ER32
ER 40	M50 x 1,5	63	25,5	58	09-UM-ER40
ER 50	M64 x 2,0	78	35,5	72	09-UM-ER50

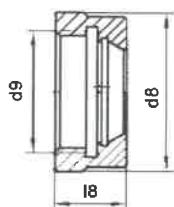

Sechskant Hexagonal

Für SZ / For collet	d9 mm	d8 mm	L8 mm	SW	Art.-Nr. / Order no.
ER 16	M22 x 1,5	28	17,5	25	09-UM-ER16H
ER 20	M25 x 1,5	34	19	30	09-UM-ER20H

Mitnehmerringe Clutch drive rings

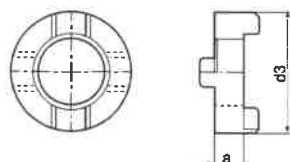

Für Fräsdorne DIN 6366 For combination end mill holders DIN 6366

Fräsdorn / Arbor	d3 mm	a mm	Art.-Nr. / Order no.
D13	28	10	09-ATR-D13
D16	32	10	09-ATR-D16
D22	40	12	09-ATR-D22
D27	48	12	09-ATR-D27
D32	58	14	09-ATR-D32
D40	70	14	09-ATR-D40
D50	90	16	09-ATR-D50

Passfedern Feather keys



Für Kombi-Fräseraufsteckdorne For combination end mill adaptors

- mit Abdrückschraube

- with push-off screw

h x b x l mm	Schraube / Screw	Art.-Nr. / Order no.
4 x 4 x 20	M2 x 4	09-PAF-M2/4
6 x 6 x 25	M3 x 5	09-PAF-M3/6
7 x 7 x 25	M3 x 6	09-PAF-M3/7
8 x 7 x 28	M3 x 6	09-PAF-M3/8
10 x 8 x 32	M3 x 6	09-PAF-M3/10

Spannschrauben Clamping screw



Für Weldon Spannfutter, DIN 1835B For Weldon chucks, DIN 1835B

Für Ø / For Ø mm	Gewinde / Thread mm	L mm	Art.-Nr. / Order no.
6	M6	10	09-WSS-M6/10
8	M8	10	09-WSS-M8/10
10	M10	12	09-WSS-M10/12
12-14	M12	16	09-WSS-M12/16
16-18	M14	16	09-WSS-M14/16
20	M16	16	09-WSS-M16/16
25	M18 x 2	20	09-WSS-M18/20
32-40	M20 x 2	20	09-WSS-M20/20

Austreiber Ejectors



MK / MT	Länge / Length mm	Art.-Nr. / Order no.
0	90	01-2000
1+2	140	01-2002
3	190	01-2003
4	225	01-2004
5+6	265	01-2005

Halbautomatische Austreiber Half automatic ejectors



- Einhandbedienung
- Vermeidung von Spindelbeschädigungen beim Lösen der Werkzeuge
- *single-hand operation*
- *no risk of damage to the spindle when removing the tools*

MK / MT	Länge / Length mm	Art.-Nr. / Order no.
1+2+3	317	01-8003
4+5+6	380	01-8006

Schraubquerkeile Driving tenons



- zum Spannen von Kegelschäften mit Mitnehmerklappen und Querkeilschlitz
- große Sicherheit durch festen Sitz
- schnelles Spannen und Lösen mit einer Schraube
- Schonung der Spindellager
- *secure clamping of taper shanks with tenons and driving slots*
- *higher safety thanks to tight fit*
- *fast clamping and removing with one screw*
- *less impact on spindle bearings*

Innen-MK / Internal MT	Für Spindel-Ø / For spindle-Ø mm	Art.-Nr. / Order no.
3	36	09-SQ-3-36
4	48	09-SQ-4-48
4	63	09-SQ-4-63
5	63	09-SQ-5-63
5	80	09-SQ-5-80
6	100	09-SQ-6-100

Kühlmittelröhrchen Coolant tubes



Für / For HSK	D mm	F mm	Art.-Nr. / Order no.
32	6	M10x1	17-KMR32
40	8	M12x1	17-KMR40
50	10	M16x1	17-KMR50
63	12	M18x1	17-KMR63
80	14	M20x1,5	17-KMR80
100	16	M24x1,5	17-KMR100

Montagehilfen Assembly supports



Montagehilfe, Aluminium Assembly support, aluminium

A x B mm	Für DIN 2080, 69871, ANSI CAT, MAS BT / For DIN 2080, 69871, ANSI CAT, MAS BT	Art.-Nr. / Order no.
80 x 75	ISO-DIN-CAT-BT30	09-TAL30
90 x 85	ISO-DIN-CAT-BT40	09-TAL40
120 x 115	ISO-DIN-CAT-BT50	09-TAL50

Montageblock, schwenkbar Assembly support, tiltable

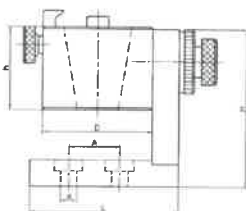

Größe / Size	D mm	h mm	d mm	H mm	A mm	L mm	Art.-Nr. / Order no.
SK 30 / BT 30	88	50	11	132	55	111	47-MBSK-30
SK 40 / BT 40	93	57	11	132	55	111	47-MBSK-40
SK 50 / BT 50	118	62	11	176	55	111	47-MBSK-50
VDI 16	78	50	11	132	55	111	47-MBS-16
VDI 20	83	50	11	132	55	111	47-MBS-20
VDI 25	93	57	11	132	55	111	47-MBS-25
VDI 30	93	57	11	132	55	111	47-MBS-30
VDI 40	102	57	11	132	55	111	47-MBS-40
VDI 50	118	62	11	132	55	111	47-MBS-50
HSK 40	88	50	11	132	55	111	47-MBHSK-40
HSK 50	93	57	11	132	55	111	47-MBHSK-50
HSK 63	98	57	11	132	55	111	47-MBHSK-63
HSK 100	135	62	11	132	55	111	47-MBHSK-100

Montageblock DIN / ISO / BT Assembly support DIN / ISO / BT

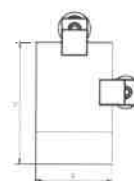
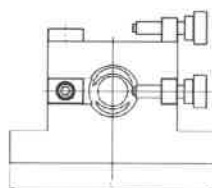
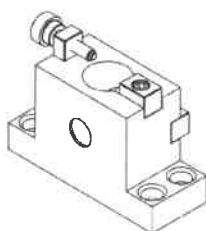

Kegel / Shank	H mm	B mm	L mm	Art.-Nr. / Order no.
30	75	47	126	09-MBW-30
40	104	63	161	09-MBW-40
50	155	98	182	09-MBW-50