



PORTA HERRAMIENTAS ESTÁTICOS TORNO CNC

PROGRAMA

MORI SEIKI / DMG MORI - NL MODELOS

NL / NLX 1500/2000 /2500/3000 (12)
NT4000/4200/4250/4300/5000/5400
NZL 2000/2500
NZX 2500 (12)

MODELOS COMPATIBLES:

Goodway G4
GS 2000/2600/2800/3000/3300/3600

PAG. 5-10

MORI SEIKI / DMG MORI - NZ MODELOS

NZ 1500/2000 / 3100
NT / NTZ 1000/2000/3000/3100/3150/3200
NZ / NZX 2000/2500 (16)
NL / NLX 1500/2000/2500 (20)
DURA TURN 2050/2550 MC

MODELOS COMPATIBLES:

Goodway G4
GS 2000/2600/2800/3000/3300/3600

PAG. 11-15

MORI SEIKI / DMG MORI - SL MODELOS

CL200/203
SL20/25
SL 200/203/204/250/253/254
(MC,SMC) - 2500Y
ZL/DL 200/250 (MC)

MODELOS COMPATIBLES:

Goodway GS200/260/280
Goodway GA2000/2600/
2800/3000/33000/3600

PAG. 16-20

MORI SEIKI / DMG MORI - SL MODELOS

SL/ZL 150/153/154
DL150

PAG. 21-24

DOOSAN - BMT 75 MODELOS

PUMA 400/480 (M,LM,XLM)
PUMA 500 (M)
PUMA V550 (M)
PUMA VT750 (TM,25P)

MODELOS COMPATIBLES:

SAMSUNG PL 45LM
HYUNDAI WIA LV800RM/SKT-V80R/RM
SKT400M/MA/MC/LMC
HWACHEON HI-TECH 550/700/7026
VT-550

PAG. 25

DOOSAN - BMT 65 MODELOS

PUMA 2100/2600(M,LM,MS,LMS)
(Y,LY,SY,LSY)
PUMA 300 (M,MS,MB,MC)
PUMA 3100 (M,LM,LY,XLM,XLY,ULM,ULY)
PUMA MX2000/2500/2600 (T,ST)
PUMA TT2000/2500 (MS,MY,SY)
PUMA TX200 (M,Y,YY)
PUMA V400 (M)-VT450 (M,25P)

MODELOS COMPATIBLES:

SAMSUNG PL 20/25M-PL 35LM-PL2000/2500Y
HYUNDAI WIA L300M/MS/-L2100SY
LM2000/2500TTM/2500TTMS/2500TTSY
SKT200/250/250(TTM,MS,SY)/300 (M,MS)
CUTEX-240 / HI/TECH 200/T2-SERIES
HI-TECH 300/400
VT450 /VTURN-A26

PAG. 26-28

PROGRAMA

<p>DOOSAN - BMT 55 MODELOS LYNX 300 (M) PUMA 230/240/280 (M,LM,S) PUMA 1500/2000/2500 (M,LM,S) PUMA 2100 (Y,LY,SY,LSY) PUMA GT 2100M PUMA H 250TM PUMA MX 2100 (ST,LST) PUMA TL2000/2500 (M,LM) PUMA TT1500/1800 (MS,SY)</p>	<p>MODELOS COMPATIBLES: SAMSUNG PL 240LM HARDINGE T-51/65 SUPER PRECISION-H51 HYUNDAI WIA L230 LMSA SKT-160/180 TTMS/TTSY LM1600/1800TTSY HWACHEON CUTEX-160/240/T2</p>
PAG. 29-31	
<p>DOOSAN - BMT 45 MODELOS LYNX 220 (M,MSLM) PUMA MX 1600 (ST)</p>	<p>MODELOS COMPATIBLES: SAMSUNG PL 1600M/MC HARDINGE T-42 SUPER PRECISION</p>
PAG. 32-33	
<p>BIGLIA MODELOS B301-B445-B470-B501 (Y-S) B510-B545-B550-B565-B650--B658 B1200-B446-B465-B754-B765-B750 (16)-B1250(16)</p>	
PAG. 34-38	
<p>BIGLIA MODELOS B436 Y2</p>	
PAG. 39-42	
<p>NAKAMURA - WT 150 MODELOS WT 150/250 WTW 150 WTS 150 WT 20II (M,MY) TW 10 SUPER NTJ/NTM3 SC 150/250</p>	<p>MODELOS COMPATIBLES: CMZ TX 52/66</p>
PAG. 43-46	
<p>NAKAMURA - WT 100 MODELOS WT 100 - WY 100 NTY 3 - NTJ100</p>	
PAG. 47-50	

PROGRAMA

<p>CMZ MODELOS TBI 520 / TL 20/25 / TC 15/20/25/30/35 / TA15M/Y/MS/MY/YS-TA 20M/Y/MS/MY/YS TA 25M/Y/MS/MY/YS-TA 30M/Y/MS/MY/YS</p>	
PAG. 51-56	
<p>CMZ MODELOS TL 15T/M/TM/S/MS TB46/67 M/CM</p>	<p>MODELOS COMPATIBLES: MIYANO ABX 51/64 THY/SYY</p>
PAG. 57-59	
<p>HAAS MODELOS SL20/SL30 ST20/ST25/ST30</p>	<p>MODELOS COMPATIBLES: OKUMA LB15/25/300</p>
PAG. 60-61	
<p>HAAS MODELOS SL10 ST10/ST15</p>	<p>MODELOS COMPATIBLES: OKUMA LLC 152 S</p>
PAG. 62	
<p>OKUMA MODELOS LB2000 EX/LB2500 EX/LB3000 EX (M-MW-MY-MYW) LU2000 EX/LU2500 EX/LU3000 EX (M-MW-MY) GENOS L300 (MY-MW-MYW)</p>	
PAG. 63-65	
<p>MURATEC MODELOS MT 12 MT 200</p>	
PAG. 66-67	
<p>GOODWAY MODELOS GLS 150 SERIES GLS 200 SERIES</p>	
PAG. 68	
<p>GOODWAY MODELOS GA 200/260/280 GS 200/230/260/280 GA 2000/2600/2800/3000/3300/3600</p>	
PAG. 69	
RECAMBIOS Y ACCESORIOS PARA PORTA HERRAMIENTAS	
PAG. 70-71	
PORTA HERRAMIENTAS DIN/69881	
PAG. 72-81	

MORI SEIKI / DMG MORI - NL

MODELOS

NL / NLX 1500/2000 /2500/3000 (12)
NT4000/4200/4250/4300/5000/5400
NZL 2000/2500
NZX 2500 (12)

MODELOS COMPATIBLES:

Goodway G4
GS 2000/2600/2800/3000/3300/3600

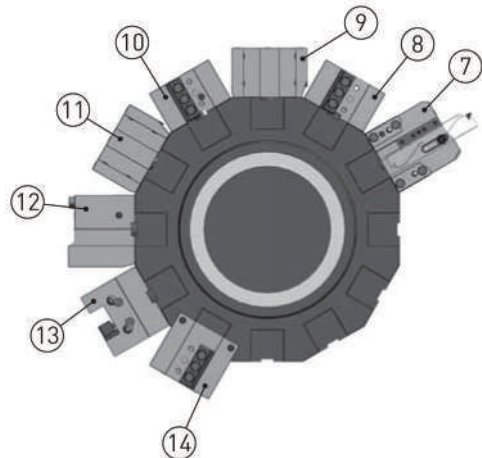
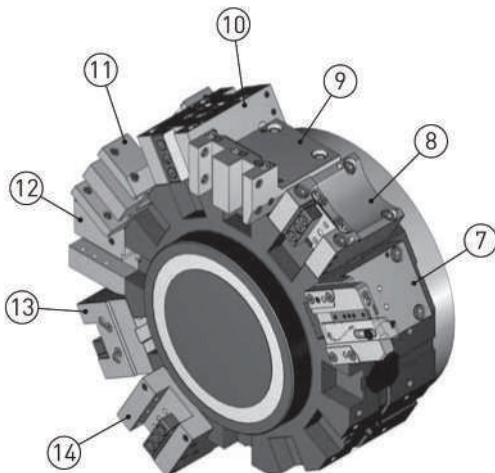
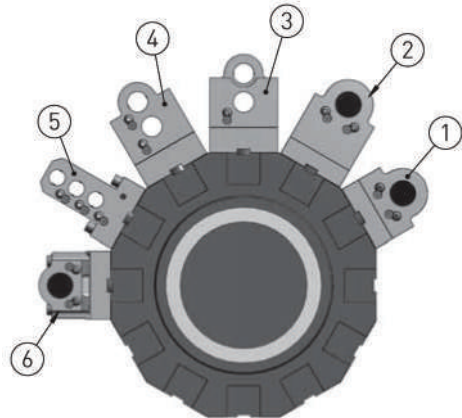
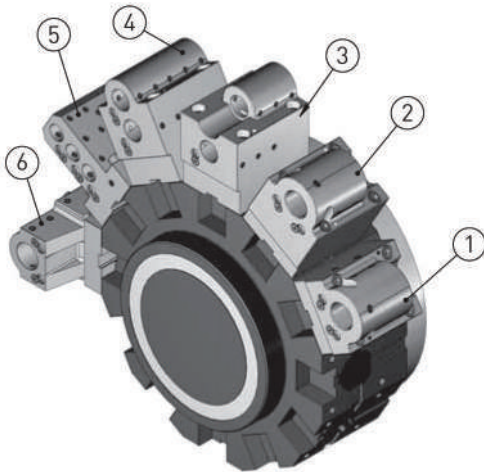
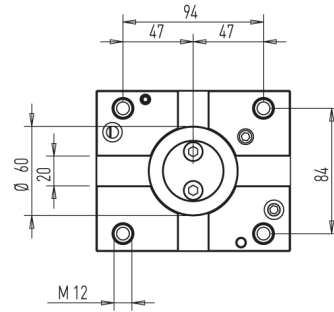

ERI Tooling Systems **PORTA HERRAMIENTAS / TORNO CNC**

MORI SEIKI / DMG MORI - NL

MODELOS

NL / NLX 1500/2000 /2500/3000 (12)
 NT4000/4200/4250/4300/5000/5400
 NZL 2000/2500
 NZX 2500 (12)

MODELOS COMPATIBLES:

Goodway G4
 GS 2000/2600/2800/3000/3300/3600

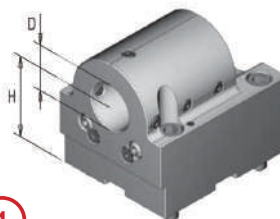
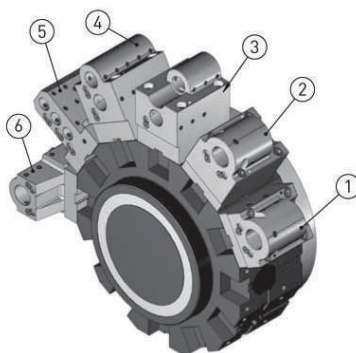
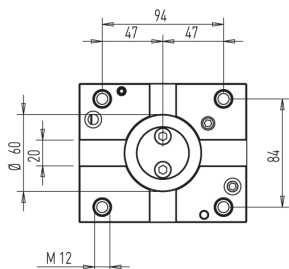

1

REFERENCIA	DMG MORI	D	H	REFRIGERACIÓN	
				INTERNA	EXTERNA
TOIM8C40	T10097	40	80	X	✓
TOIM8C40R	T13128	40	80	✓	✓
TOIM8C50	T10098	50	80	X	✓
TOIM8C50R	/	50	80	✓	✓

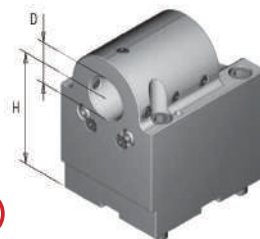
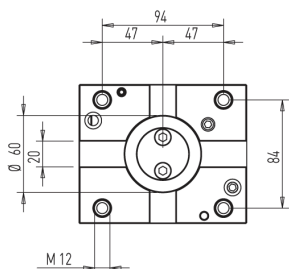

2

REFERENCIA	DMG MORI	D	H	REFRIGERACIÓN	
				INTERNA	EXTERNA
TOIM8C40H120	T10113	40	120	X	✓
TOIM8C40RH120	T13131	40	120	✓	✓
TOIM8C50H120	T10114	50	120	X	✓

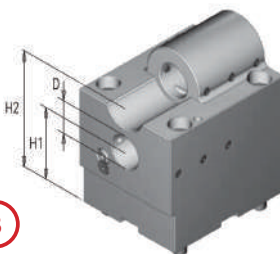
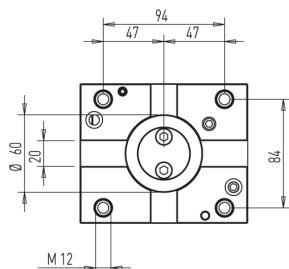

3

REFERENCIA	DMG MORI	D	H1	H2	REFRIGERACIÓN	
					INTERNA	EXTERNA
TOIM8D32	T10096	32	80	125	✓	✓

12

MORI SEIKI / DMG MORI - NL

MODELOS

NL / NLX 1500/2000 /2500/3000 (12)
 NT4000/4200/4250/4300/5000/5400
 NZL 2000/2500
 NZX 2500 (12)

MODELOS COMPATIBLES:

Goodway G4
 GS 2000/2600/2800/3000/3300/3600

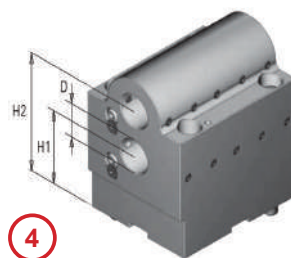
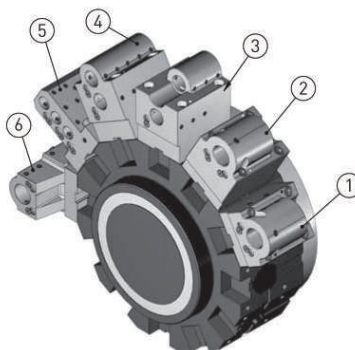
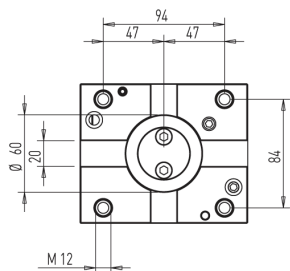

4

REFERENCIA	DMG MORI	D	H1	H2	REFRIGERACIÓN	
					INTERNA	EXTERNA
TOIM8D32L	/	32	80	125	✓	✓

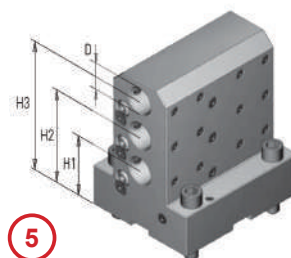
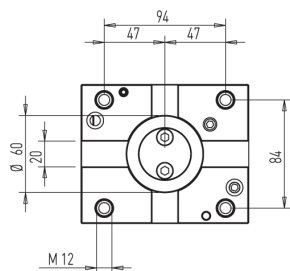

5

REFERENCIA	DMG MORI	D	H1	H2	H3	REFRIGERACIÓN	
						INTERNA	EXTERNA
TOIM8T25L	T10104	25	60	95	130	✓	✓

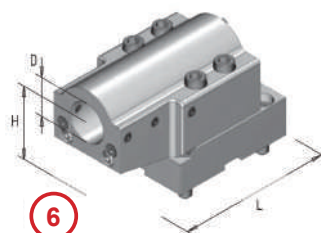
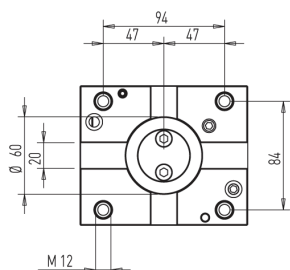

6

REFERENCIA	DMG MORI	D	H	L	REFRIGERACIÓN	
					INTERNA	EXTERNA
TOIM87M6-7M6L40	T23018 T10038	40	80	190	✓	✓
TOIM87M6-7M6L50	T23018 T10038	50	80	190	✓	✓

MORI SEIKI / DMG MORI - NL

MODELOS

NL / NLX 1500/2000 /2500/3000 (12)
 NT4000/4200/4250/4300/5000/5400
 NZL 2000/2500
 NZX 2500 (12)

MODELOS COMPATIBLES:

Goodway G4
 GS 2000/2600/2800/3000/3300/3600

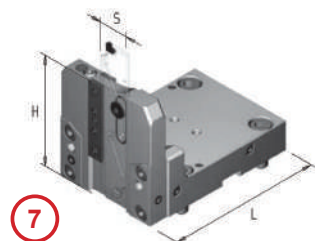
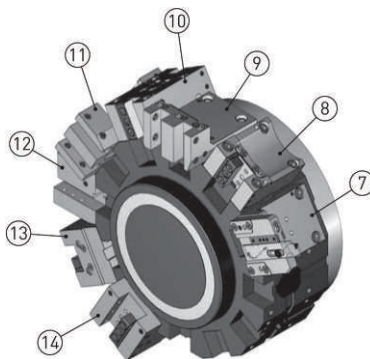
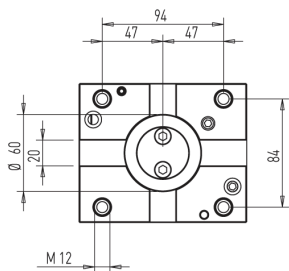

REFERENCIA	DMG MORI	S	H	L	REFRIGERACIÓN	
					INTERNA	EXTERNA
TOEM8B32	/	ISCAR 32	95	160	✓	✓

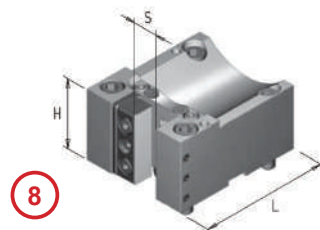
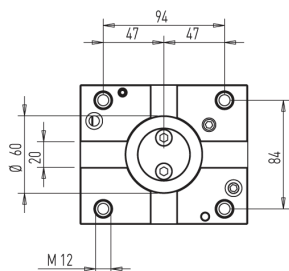

REFERENCIA	DMG MORI	S	H	L	REFRIGERACIÓN	
					INTERNA	EXTERNA
TOE8M8V40	T00187	20X20	65	130	X	✓
TOE8M8V50	T00186	25X25	70	130	X	✓

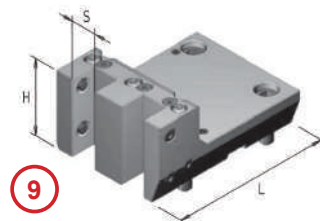
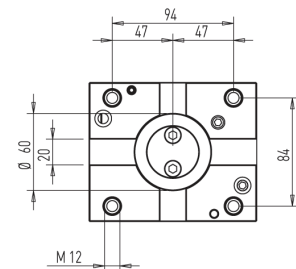

REFERENCIA	DMG MORI	S	H	L	REFRIGERACIÓN	
					INTERNA	EXTERNA
TOEM8V25D	/	25X25	78	164	X	✓

12

MORI SEIKI / DMG MORI - NL

MODELOS

NL / NLX 1500/2000 /2500/3000 (12)
 NT4000/4200/4250/4300/5000/5400
 NZL 2000/2500
 NZX 2500 (12)

MODELOS COMPATIBLES:

Goodway G4
 GS 2000/2600/2800/3000/3300/3600

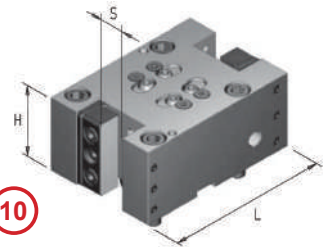
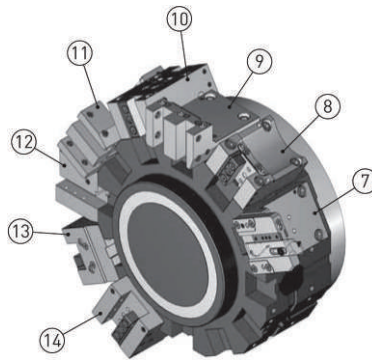
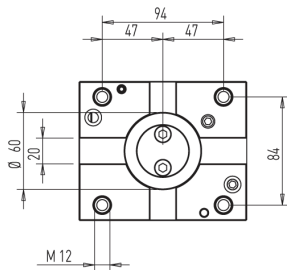

REFERENCIA	DMG MORI	S	H	L	REFRIGERACIÓN	
					INTERNA	EXTERNA
TOEM8D40	T00185	20X20	65	150	X	✓
TOEM8D50	T00184	25X25	70	155	X	✓

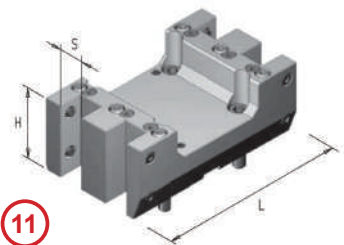
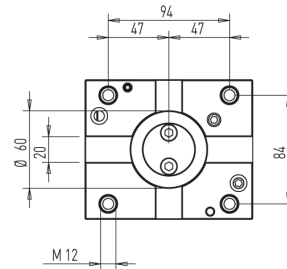

REFERENCIA	DMG MORI	S	H	L	REFRIGERACIÓN	
					INTERNA	EXTERNA
TOEM8D25Q	/	25X25	78	197	X	✓

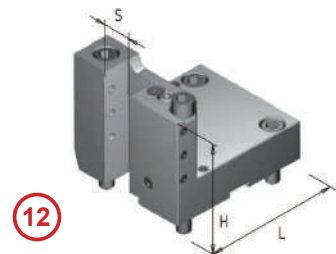
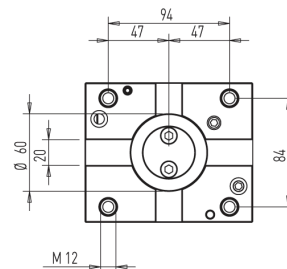

REFERENCIA	DMG MORI	S	H	L	REFRIGERACIÓN	
					INTERNA	EXTERNA
TOEM8B25	T00197	25X25	95	130	X	✓

12

ERI Tooling Systems **PORTA HERRAMIENTAS / TORNO CNC**

MORI SEIKI / DMG MORI - NL

MODELOS

NL / NLX 1500/2000 /2500/3000 (12)
 NT4000/4200/4250/4300/5000/5400
 NZL 2000/2500
 NZX 2500 (12)

MODELOS COMPATIBLES:

Goodway G4
 GS 2000/2600/2800/3000/3300/3600

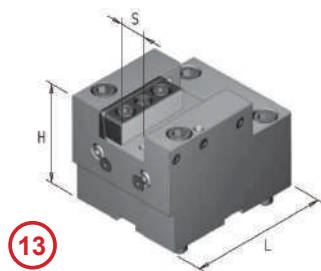
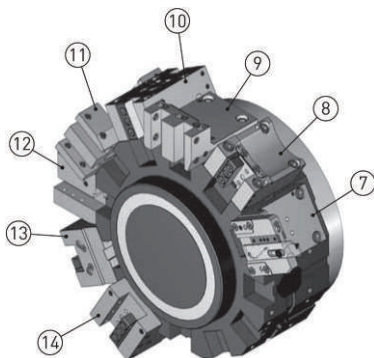
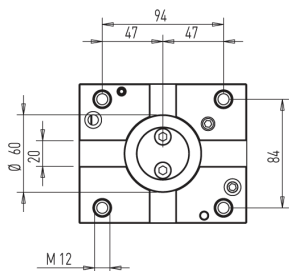

13

REFERENCIA	DMG MORI	S	H	L	REFRIGERACIÓN	
					INTERNA	EXTERNA
TOEM8C40	T03006	20X20	70	130	✓	✓
TOEM8C50	T03005	25X25	100	130	✓	✓

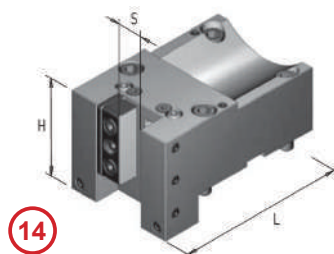
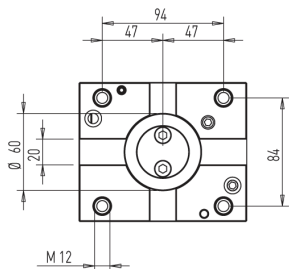

14

REFERENCIA	DMG MORI	S	H	L	REFRIGERACIÓN	
					INTERNA	EXTERNA
TOEM8V50L	T00197	25X25	98	169	X	✓

12



MORI SEIKI / DMG MORI - NZ

MODELOS

NZ 1500/2000 / 3100

NT / NTZ 1000/2000/3000/3100/3150/3200

NZ / NZX 2000/2500 (16)

MODELOS

NL / NLX 1500/2000/2500 (20)

DURA TURN 2050/2550 MC

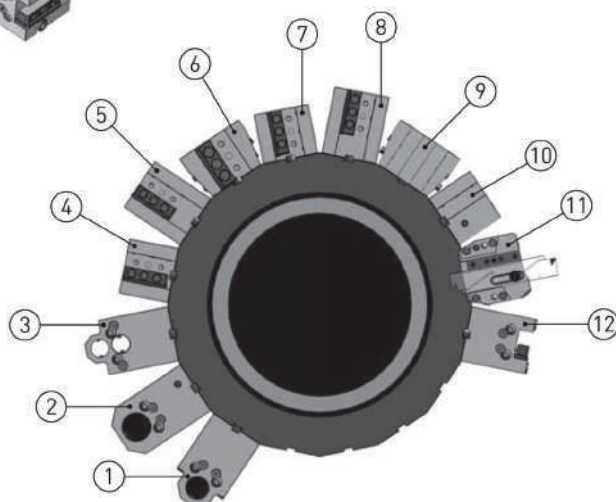
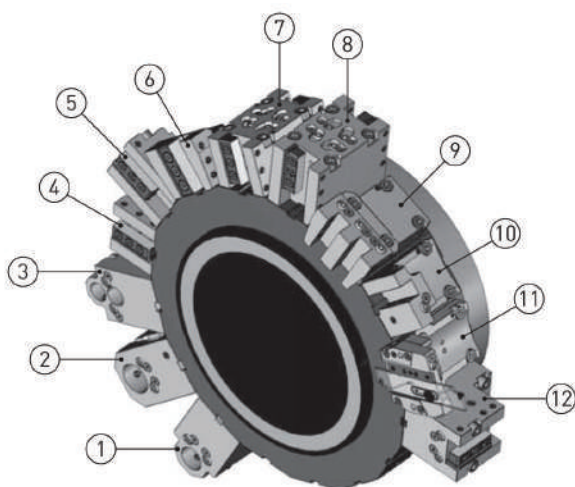
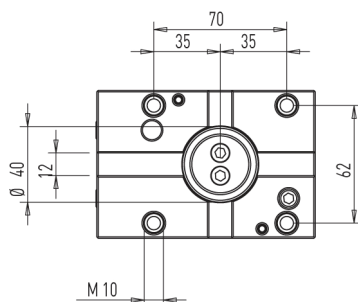

MORI SEIKI / DMG MORI - NZ

MODELOS

NZ 1500/2000 / 3100
 NT / NTZ 1000/2000/3000/3100/3150/3200
 NZ / NZX 2000/2500 (16)

MODELOS

NL / NLX 1500/2000/2500 (20)
 DURA TURN 2050/2550 MC

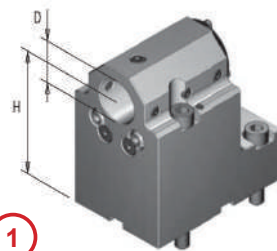
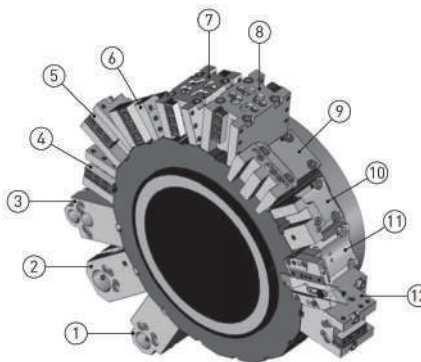
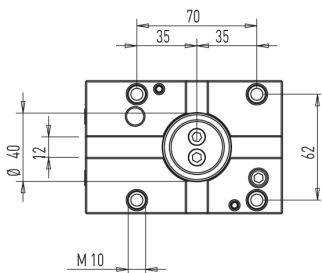

REFERENCIA	DMG MORI	D	H	REFRIGERACIÓN	
				INTERNA	EXTERNA
TOIM5C32	T10115	32	100	X	✓
TOIM5C32R	T13132	32	100	✓	✓

12

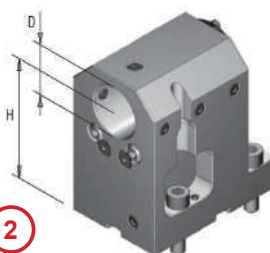
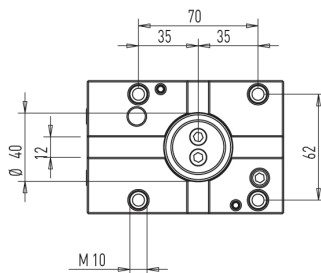

REFERENCIA	DMG MORI	D	H	REFRIGERACIÓN	
				INTERNA	EXTERNA
TOIM5C40	/	40	100	X	✓
TOIM5C40R	/	40	100	✓	✓

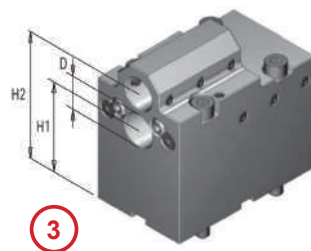
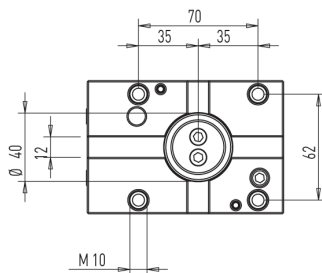

REFERENCIA	DMG MORI	D	H1	H2	REFRIGERACIÓN	
					INTERNA	EXTERNA
TOIM5D25	T10117	25	75	105	✓	✓

MORI SEIKI / DMG MORI - NZ

MODELOS

NZ 1500/2000 / 3100
 NT / NTZ 1000/2000/3000/3100/3150/3200
 NZ / NZX 2000/2500 (16)

MODELOS

NL / NLX 1500/2000/2500 (20)
 DURA TURN 2050/2550 MC

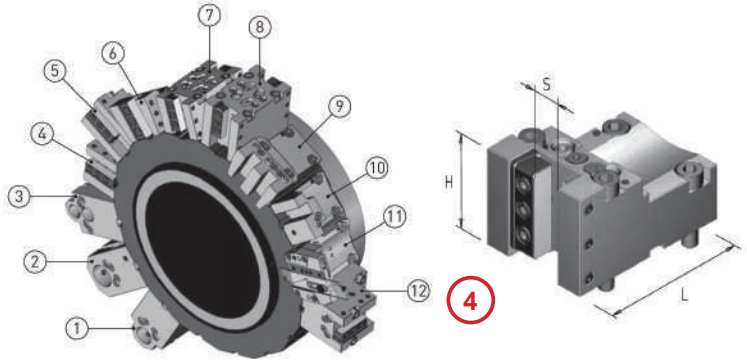
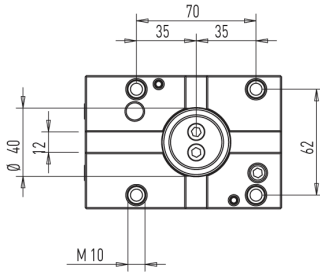

REFERENCIA	DMG MORI	S	H	L	REFRIGERACIÓN	
					INTERNA	EXTERNA
TOEM5V40	T00224	20X20	70	115	X	✓

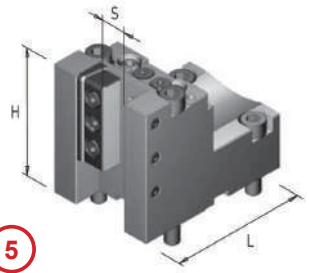
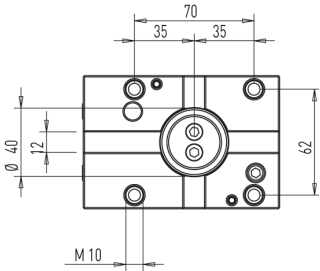

REFERENCIA	DMG MORI	S	H	L	REFRIGERACIÓN	
					INTERNA	EXTERNA
TOEM5V40H95	T00225	20X20	95	115	X	✓

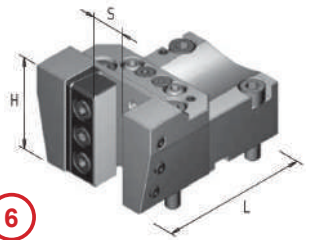
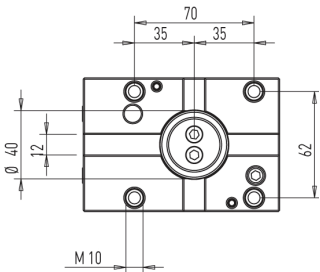

REFERENCIA	DMG MORI	S	H	L	REFRIGERACIÓN	
					INTERNA	EXTERNA
TOEM5V50	/	25X25	70	124	X	✓

12

MORI SEIKI / DMG MORI - NZ

MODELOS

NZ 1500/2000 / 3100
 NT / NTZ 1000/2000/3000/3100/3150/3200
 NZ / NZX 2000/2500 (16)

MODELOS

NL / NLX 1500/2000/2500 (20)
 DURA TURN 2050/2550 MC

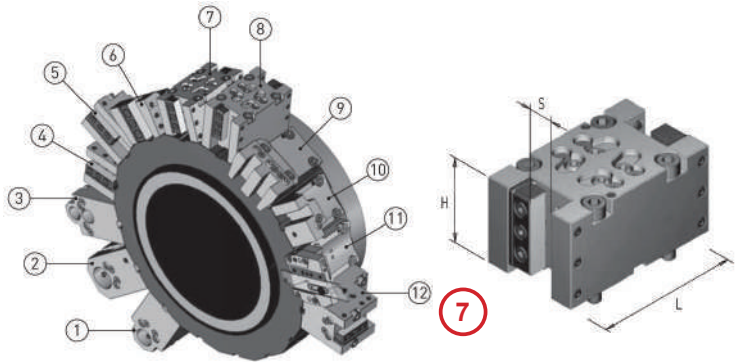
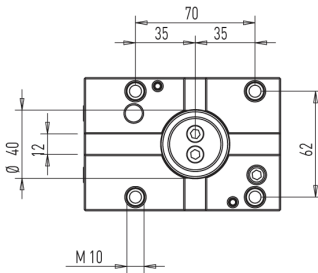

7

REFERENCIA	DMG MORI	S	H	L	REFRIGERACIÓN	
					INTERNA	EXTERNA
TOEM5D40	T00228	20X20	70	130	X	✓

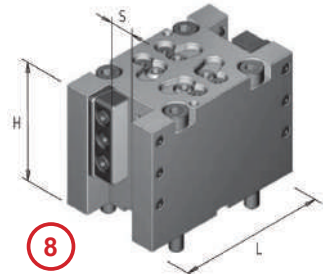
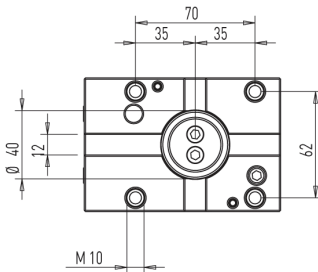

8

REFERENCIA	DMG MORI	S	H	L	REFRIGERACIÓN	
					INTERNA	EXTERNA
TOEM5D40H95	T00226	20X20	95	130	X	✓

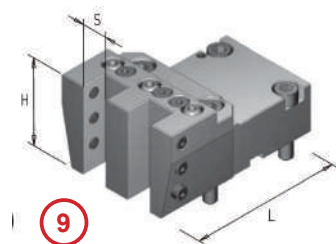
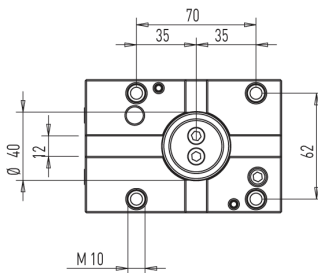

9

REFERENCIA	DMG MORI	S	H	L	REFRIGERACIÓN	
					INTERNA	EXTERNA
TOEM5V20D	/	20X20	70	139	X	✓

12

MORI SEIKI / DMG MORI - NZ

MODELOS

NZ 1500/2000 / 3100
 NT / NTZ 1000/2000/3000/3100/3150/3200
 NZ / NZX 2000/2500 (16)

MODELOS

NL / NLX 1500/2000/2500 (20)
 DURA TURN 2050/2550 MC

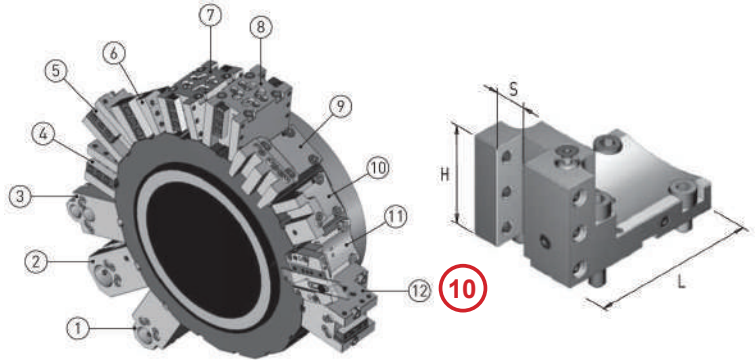
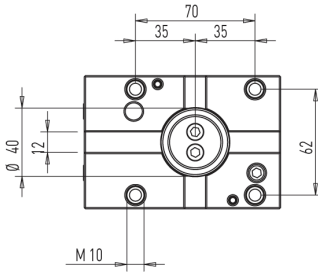

REFERENCIA	DMG MORI	S	H	L	REFRIGERACIÓN	
					INTERNA	EXTERNA
TOEM5B20	T00251	20X20	70	115	X	✓

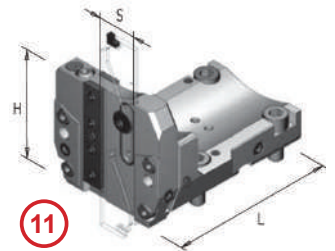
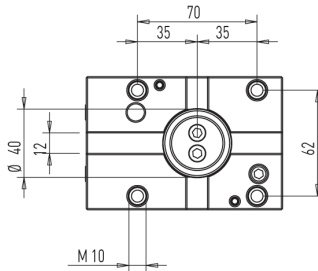

REFERENCIA	DMG MORI	S	H	L	REFRIGERACIÓN	
					INTERNA	EXTERNA
TOEM5B32	/	ISCAR 32	80	135	✓	✓

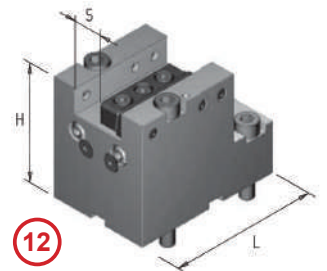
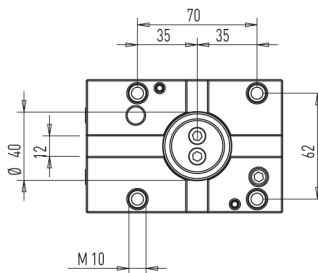

REFERENCIA	DMG MORI	S	H	L	REFRIGERACIÓN	
					INTERNA	EXTERNA
TOEM5C40	T03017	20X20	92	115	X	✓

MORI SEIKI / DMG MORI - SL

MODELOS

CL200/203
SL20/25
SL 200/203/204/250/253/254
(MC, SMC) - 2500Y
ZL/DL 200/250 (MC)

MODELOS COMPATIBLES:

Goodway GS200/260/280
Goodway GA2000/2600/2800/3000/33000/3600

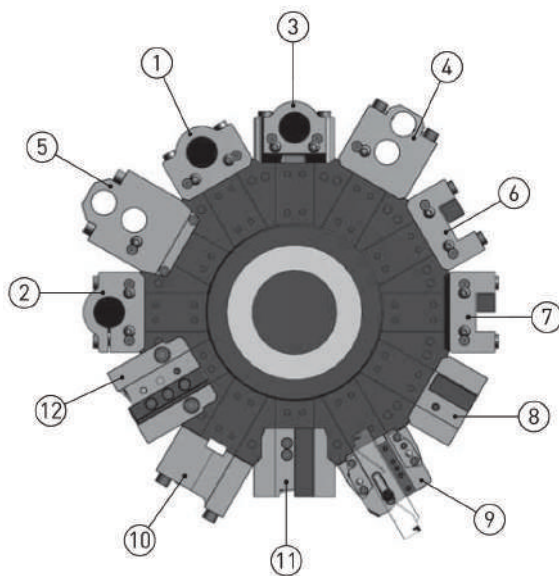
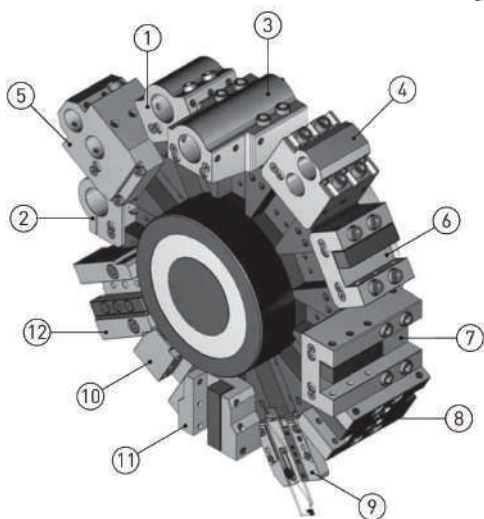
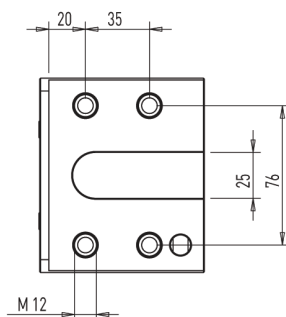

MORI SEIKI / DMG MORI - SL

MODELOS

CL200/203
 SL20/25
 SL 200/203/204/250/253/254
 (MC, SMC) - 2500Y
 ZL/DL 200/250 (MC)

MODELOS COMPATIBLES:

Goodway GS200/260/280
 Goodway GA2000/2600/2800/3000/33000/3600

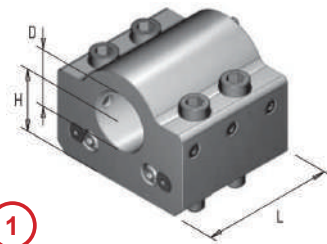
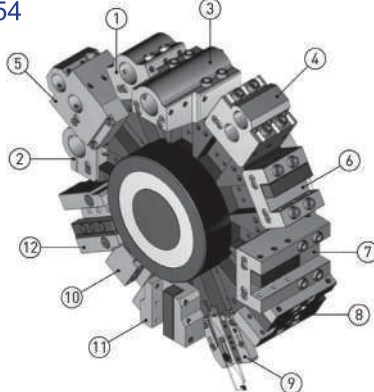
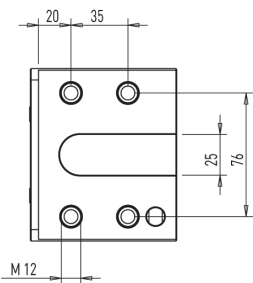

REFERENCIA	DMG MORI	D	H	L	REFRIGERACIÓN	
					INTERNA	EXTERNA
TOIM6C40	T10036	40	40	90	X	✓
TOIM6C40R	T13064	40	40	90	✓	✓
TOIM6C50	T10044	50	40	90	X	✓
TOIM6C50R	T10044	50	40	90	✓	✓

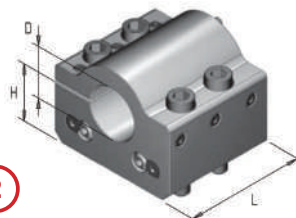
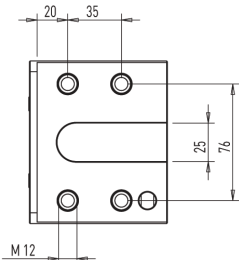

12

REFERENCIA	DMG MORI	D	H	L	REFRIGERACIÓN	
					INTERNA	EXTERNA
TOIM6C40B	/	40	40	90	X	✓

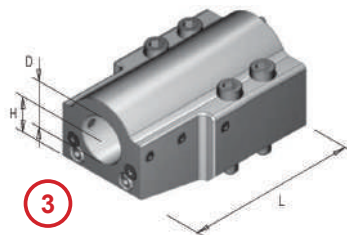
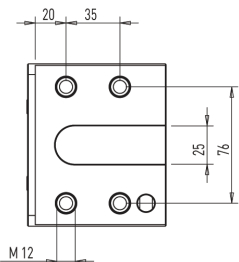

REFERENCIA	DMG MORI	D	H	L	REFRIGERACIÓN	
					INTERNA	EXTERNA
TOIM6L40	T10038	40	40	160	X	✓
TOIM6L40R	T10038	40	40	160	✓	✓
TOIM6L50	T10094	50	40	160	X	✓
TOIM6L50R	T10094	50	40	160	✓	✓

MORI SEIKI / DMG MORI - SL

MODELOS

CL200/203
SL20/25
SL 200/203/204/250/253/254
(MC,SMC) - 2500Y
ZL/DL 200/250 (MC)

MODELOS COMPATIBLES:

Goodway GS200/260/280
Goodway GA2000/2600/2800/3000/33000/3600

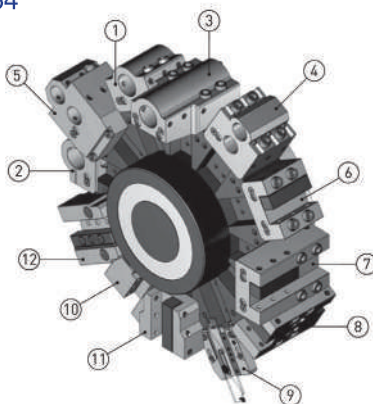
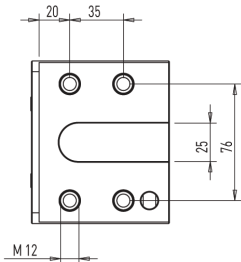

4

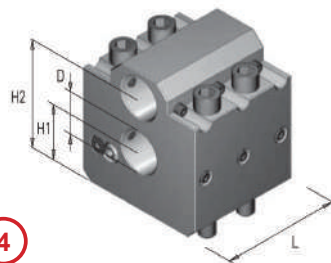

REFERENCIA	DMG MORI	D	H1	H2	L	REFRIGERACIÓN	
						INTERNA	EXTERNA
TOIM6D32	T10086	32	40	82	90	✓	✓

12

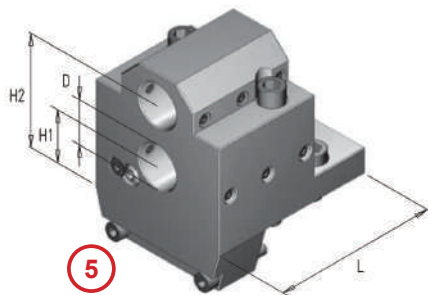
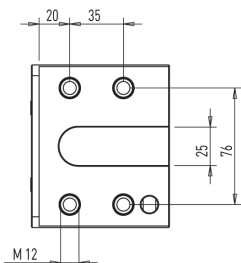

5

REFERENCIA	DMG MORI	D	H1	H2	L	REFRIGERACIÓN	
						INTERNA	EXTERNA
TOIM6D32L	T10208	32	40	85	125	✓	✓

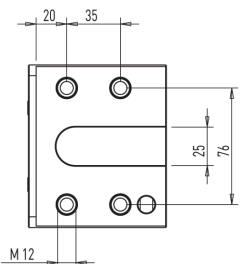

6

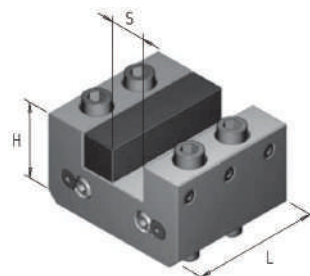

REFERENCIA	DMG MORI	S	H	L	REFRIGERACIÓN	
					INTERNA	EXTERNA
TOIM6C50	T00068	25X25	55	90	X	✓

MORI SEIKI / DMG MORI - SL

MODELOS

CL200/203
 SL20/25
 SL 200/203/204/250/253/254
 (MC, SMC) - 2500Y
 ZL/DL 200/250 (MC)

MODELOS COMPATIBLES:

Goodway GS200/260/280
 Goodway GA2000/2600/2800/3000/33000/3600

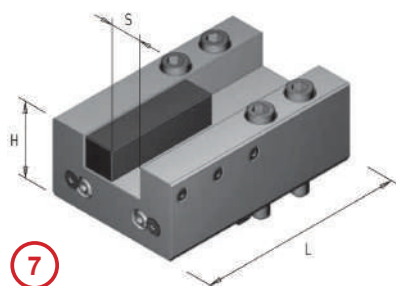
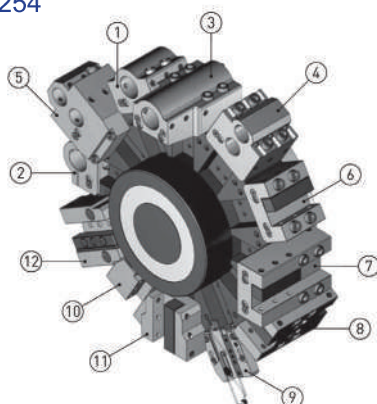
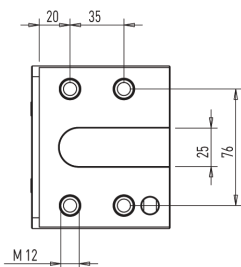

REFERENCIA	DMG MORI	S	H	L	REFRIGERACIÓN	
					INTERNA	EXTERNA
TOEM6L50	T00082	25X25	60	160	X	✓

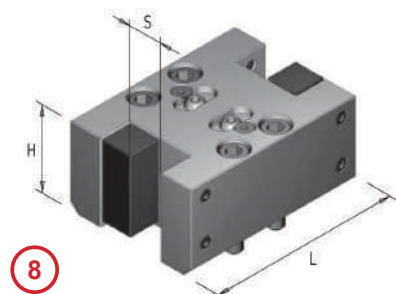
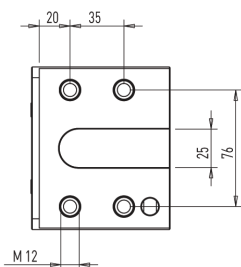

REFERENCIA	DMG MORI	S	H	L	REFRIGERACIÓN	
					INTERNA	EXTERNA
TOEM6D50	T00158	25X25	60	139	X	✓

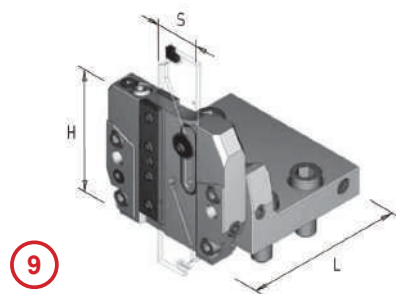
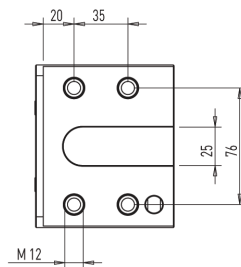

REFERENCIA	DMG MORI	S	H	L	REFRIGERACIÓN	
					INTERNA	EXTERNA
TOEM6B32	/	ISCAR 32	80	103	✓	✓

MORI SEIKI / DMG MORI - SL

MODELOS

CL200/203
 SL20/25
 SL 200/203/204/250/253/254
 (MC, SMC) - 2500Y
 ZL/DL 200/250 (MC)

MODELOS COMPATIBLES:

Goodway GS200/260/280
 Goodway GA2000/2600/2800/3000/33000/3600

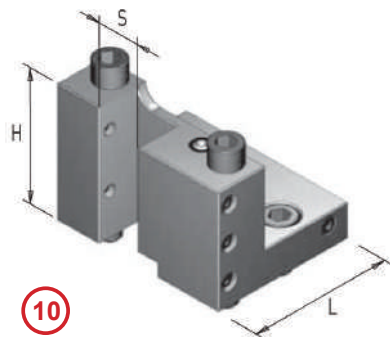
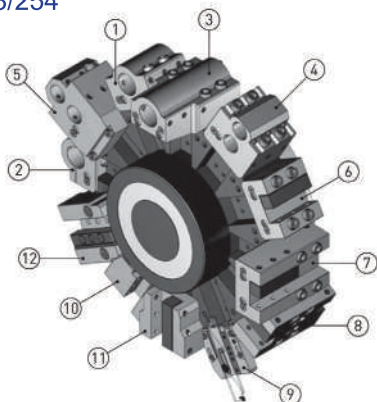
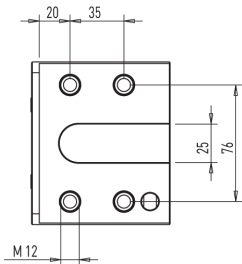

10

REFERENCIA	DMG MORI	S	H	L	REFRIGERACIÓN	
					INTERNA	EXTERNA
TOEM6B25	T00156	25X25	78	85	X	✓

12

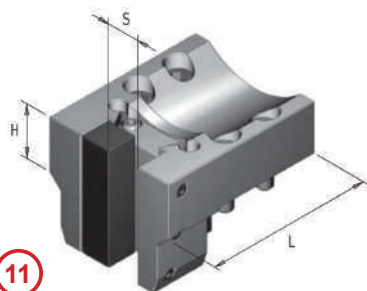
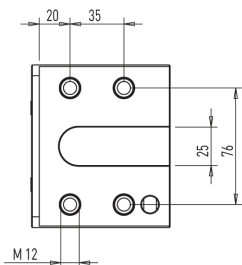

11

REFERENCIA	DMG MORI	S	H	L	REFRIGERACIÓN	
					INTERNA	EXTERNA
TOEM6V50	T00074	25X25	90	130	X	✓
TOEM6V50L	T00076	25X25	90	155	X	✓

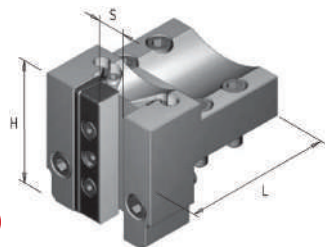
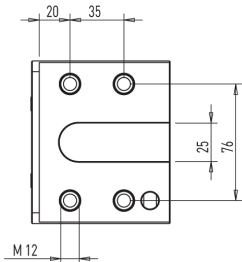

12

REFERENCIA	DMG MORI	S	H	L	REFRIGERACIÓN	
					INTERNA	EXTERNA
TOEM6T50	T00162	25X25	109	130	X	✓
TOEM6T50L	T00164	25X25	109	160	X	✓

MORI SEIKI / DMG MORI - SL

MODELOS

SL/ZL 150/153/154

DL150

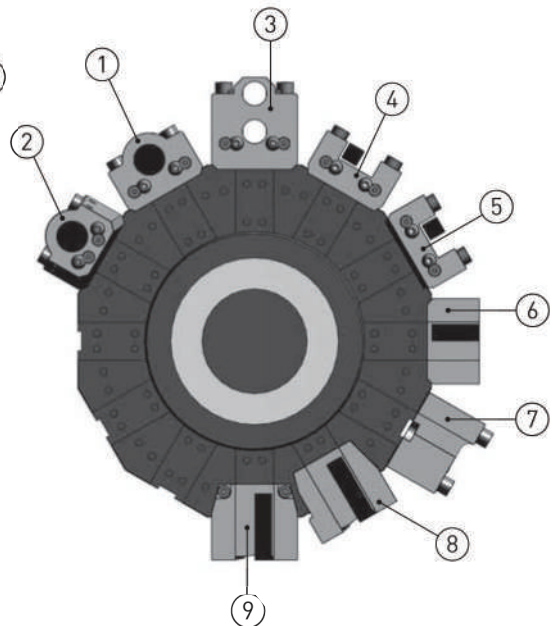
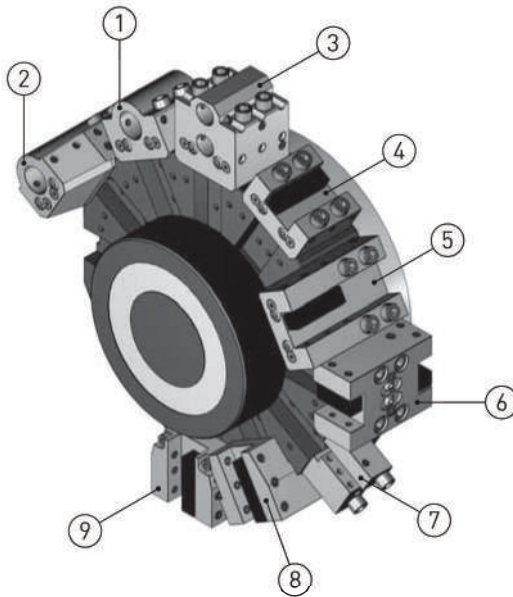
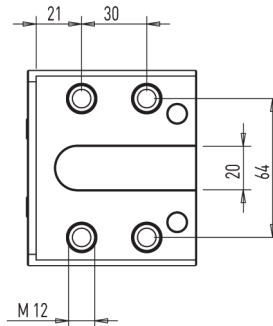

MORI SEIKI / DMG MORI - SL

MODELOS

SL/ZL 150/153/154
DL150

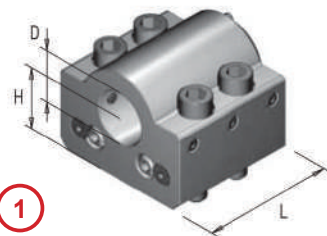
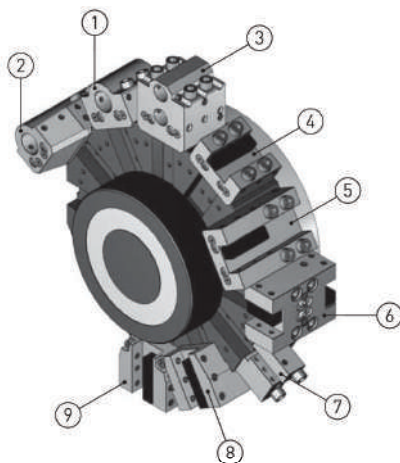
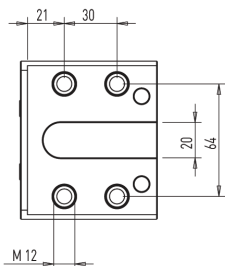

1

REFERENCIA	DMG MORI	D	H	L	REFRIGERACIÓN	
					INTERNA	EXTERNA
TOIM3C32	T10046	32	35	79	X	✓
TOIM3C32R	T13066	32	35	79	✓	✓

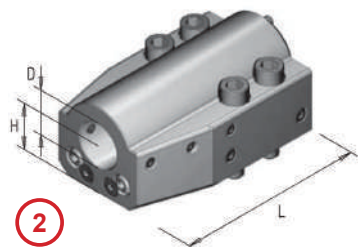
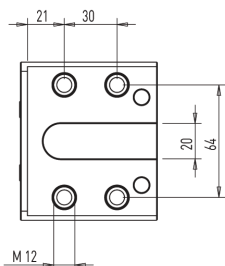

2

REFERENCIA	DMG MORI	D	H	L	REFRIGERACIÓN	
					INTERNA	EXTERNA
TOIM3L32	T10052	32	35	139	✓	✓

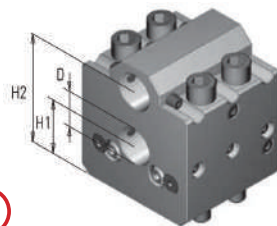
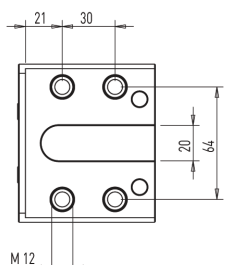

3

REFERENCIA	DMG MORI	D	H	L	REFRIGERACIÓN	
					INTERNA	EXTERNA
TOIM3D25	T10082	25	35	75	X	✓
TOIM3D25R	T10082	25	35	75	✓	✓

MORI SEIKI / DMG MORI - SL

MODELOS

SL/ZL 150/153/154
DL150

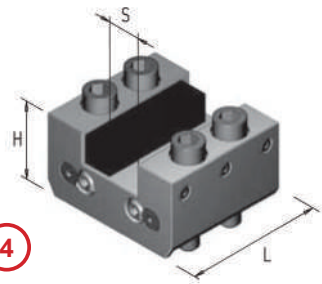
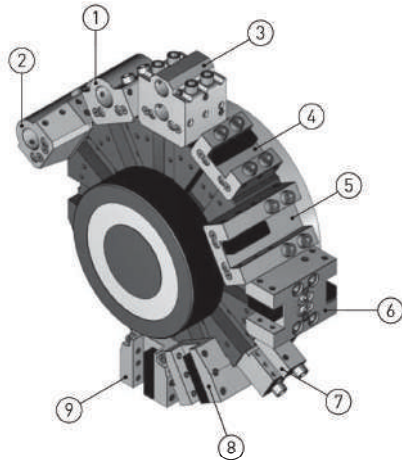
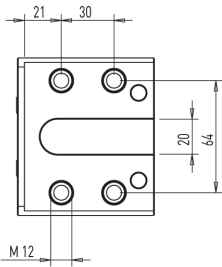

REFERENCIA	DMG MORI	S	H	L	REFRIGERACIÓN	
					INTERNA	EXTERNA
TOEM3C40	T00080	20X20	45	78	X	✓

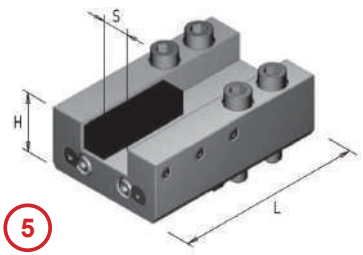
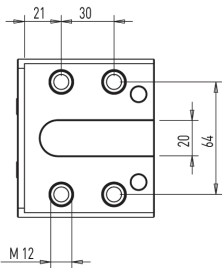

REFERENCIA	DMG MORI	S	H	L	REFRIGERACIÓN	
					INTERNA	EXTERNA
TOEM3L40	T100148	20X20	50	139	X	✓

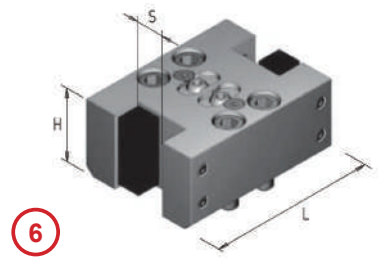
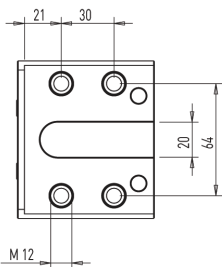

REFERENCIA	DMG MORI	S	H	L	REFRIGERACIÓN	
					INTERNA	EXTERNA
TOEM3D40	T00108	20X20	50	120	X	✓

MORI SEIKI / DMG MORI - SL

MODELOS

SL/ZL 150/153/154
DL150

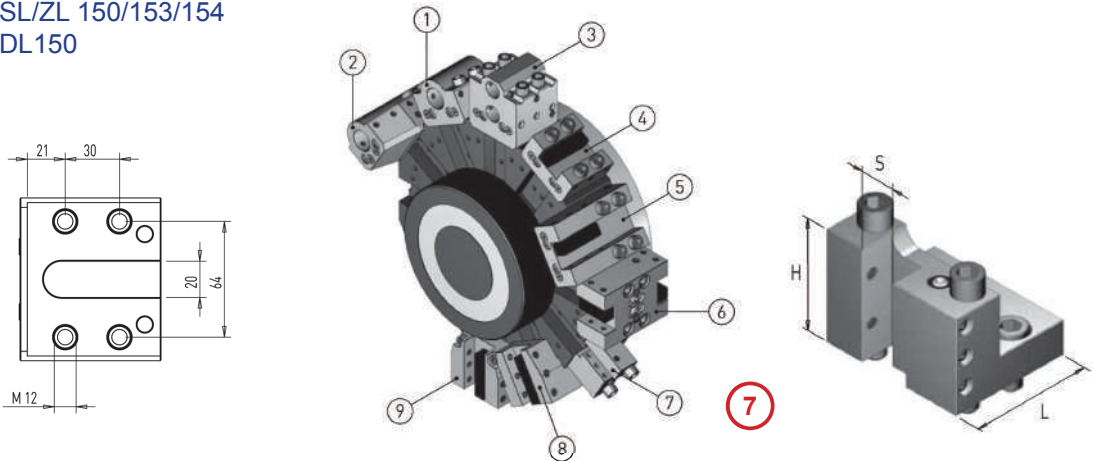

REFERENCIA	DMG MORI	S	H	L	REFRIGERACIÓN	
					INTERNA	EXTERNA
TOEM3B20	T00134	20X20	68	75	X	✓

12



REFERENCIA	DMG MORI	S	H	L	REFRIGERACIÓN	
					INTERNA	EXTERNA
TOEM3V40	T00146	20X20	35	115	X	✓



REFERENCIA	DMG MORI	S	H	L	REFRIGERACIÓN	
					INTERNA	EXTERNA
TOEM3T40	T00078	20X20	40	115	X	✓

DOOSAN - BMT 75

MODELOS

PUMA 400/480 (M,LM,XLM)
 PUMA 500 (M)
 PUMA V550 (M)
 PUMA VT750 (TM,25P)

MODELOS COMPATIBLES:

SAMSUNG PL 45LM
 HYUNDAI WIA LV800RM/SKT-V80R/RM
 SKT400M/MA/MC/LMC
 HWACHEON HI-TECH 550/700/7026
 VT-550

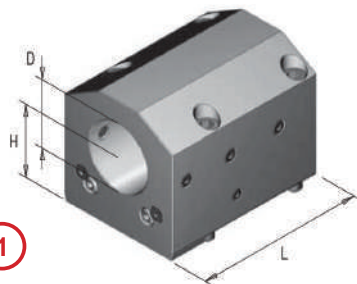
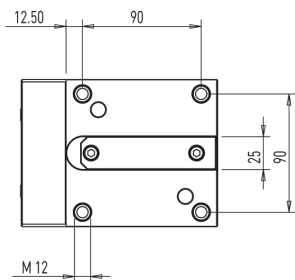
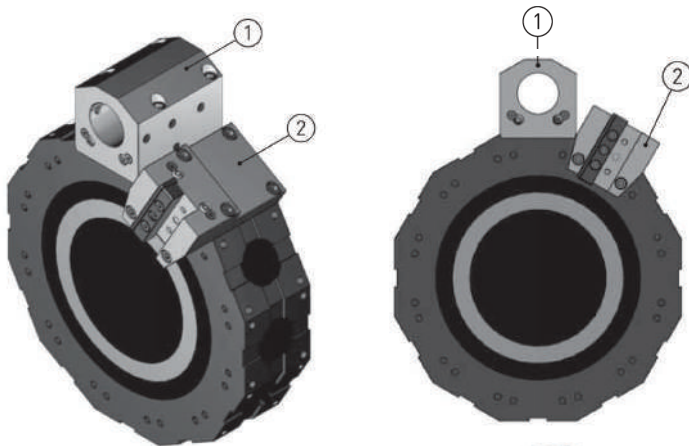

12

REFERENCIA	DOOSAN	D	H	L	REFRIGERACIÓN	
					INTERNA	EXTERNA
TOID8C60	/	60	60	149	X	✓
TOID8C60R	/	60	60	149	✓	✓

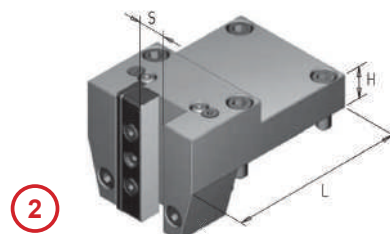
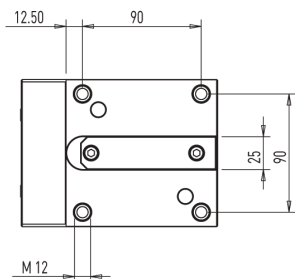

REFERENCIA	DOOSAN	S	H	L	REFRIGERACIÓN	
					INTERNA	EXTERNA
TOED8V50	/	25X25	50	165	X	✓

DOOSAN - BMT 65

MODELOS

PUMA 2100/2600(M,LM,MS,LMS)(Y,LY,SY,LSY)
 PUMA 300 (M,MS,MB,MC)
 PUMA 3100 (M,LM,LY,XLM,XLY,ULM,ULY)
 PUMA MX2000/2500/2600 (T,ST)
 PUMA TT2000/2500 (MS,MY,SY)
 PUMA TX200 (M,Y,YY)
 PUMA V400 (M)-VT450 (M,25P)

MODELOS COMPATIBLES:

SAMSUNG PL 20/25M-PL 35LM-PL2000/2500Y
 HYUNDAI WIA L300M/MS/-L2100SY
 LM2000/2500TTM/2500TTMS/2500TTSY
 SKT200/250/250(TTM,MS,SY)/300 (M,MS)
 CUTEX-240 / HI/TECH 200/T2-SERIES
 HI-TECH 300/400
 VT450 /TURN-A26

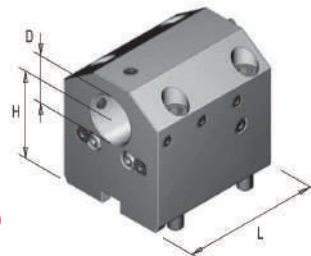
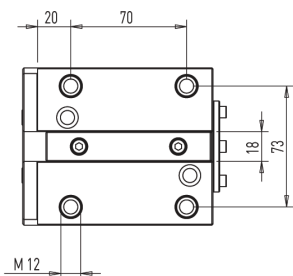
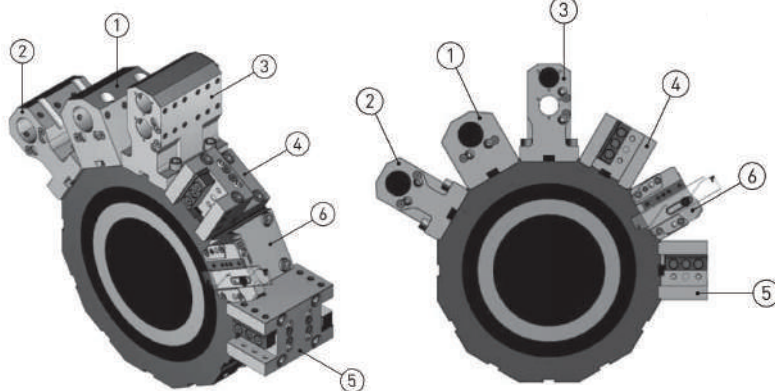

12

REFERENCIA	DOOSAN	D	H	L	REFRIGERACIÓN	
					INTERNA	EXTERNA
TOID7C40	/	40	72	115	X	✓
TOID7C40R	/	40	72	115	✓	✓

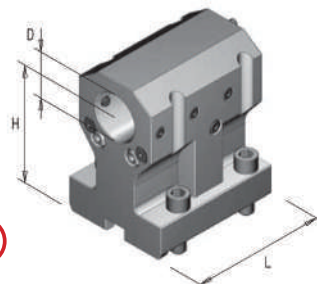
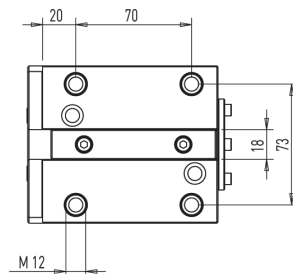

REFERENCIA	DOOSAN	D	H	L	REFRIGERACIÓN	
					INTERNA	EXTERNA
TOID7C40H100	/	40	100	115	X	✓
TOID7C40RH100	/	40	100	115	✓	✓

DOOSAN - BMT 65

MODELOS

PUMA 2100/2600(M,LM,MS,LMS)(Y,LY,SY,LSY)
 PUMA 300 (M,MS,MB,MC)
 PUMA 3100 (M,LM,LY,XLM,XLY,ULM,ULY)
 PUMA MX2000/2500/2600 (T,ST)
 PUMA TT2000/2500 (MS,MY,SY)
 PUMA TX200 (M,Y,YY)
 PUMA V400 (M)-VT450 (M,25P)

MODELOS COMPATIBLES:

SAMSUNG PL 20/25M-PL 35LM-PL2000/2500Y
 HYUNDAI WIA L300M/MS/-L2100SY
 LM2000/2500TTM/2500TTMS/2500TTSY
 SKT200/250/250(TTM,MS,SY)/300 (M,MS)
 CUTEX-240 / HI/TECH 200/T2-SERIES
 HI-TECH 300/400
 VT450 /TURN-A26

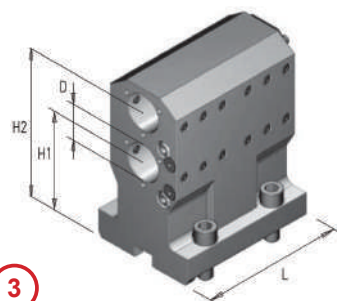
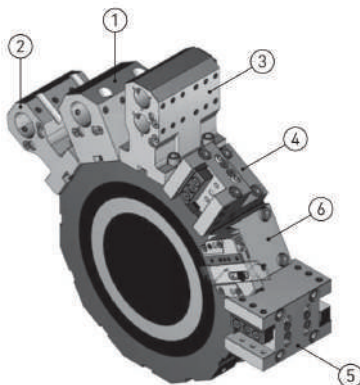
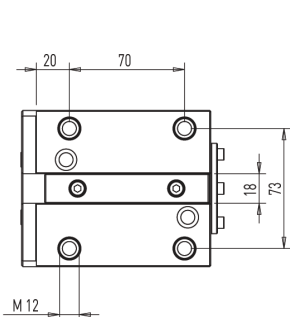

REFERENCIA	DOOSAN	D	H1	H2	L	REFRIGERACIÓN	
						INTERNA	EXTERNA
TOID7D32	/	32	85	130	125	X	✓
TOID7D32R	/	32	85	130	125	✓	✓

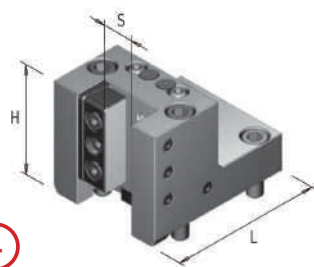
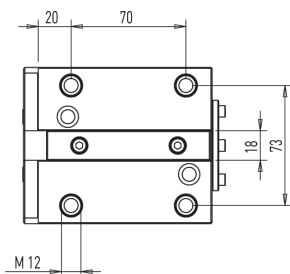

REFERENCIA	DOOSAN	S	H	L	REFRIGERACIÓN	
					INTERNA	EXTERNA
TOED7V50	/	25X25	85	120	X	✓

DOOSAN - BMT 65

MODELOS

PUMA 2100/2600(M,LM,MS,LMS)(Y,LY,SY,LSY)
 PUMA 300 (M,MS,MB,MC)
 PUMA 3100 (M,LM,LY,XLM,XLY,ULM,ULY)
 PUMA MX2000/2500/2600 (T,ST)
 PUMA TT2000/2500 (MS,MY,SY)
 PUMA TX200 (M,Y,YY)
 PUMA V400 (M)-VT450 (M,25P)

MODELOS COMPATIBLES:

SAMSUNG PL 20/25M-PL 35LM-PL2000/2500Y
 HYUNDAI WIA L300M/MS-/L2100SY
 LM2000/2500TTM/2500TTMS/2500TTSY
 SKT200/250/250(TTM,MS,SY)/300 (M,MS)
 CUTEX-240 / HI/TECH 200/T2-SERIES
 HI-TECH 300/400
 VT450 /TURN-A26

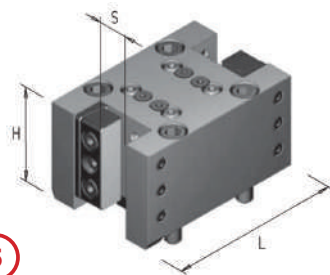
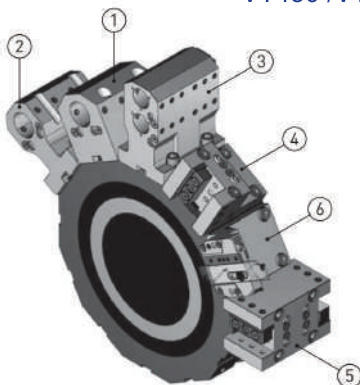
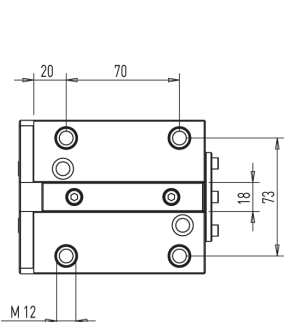

REFERENCIA	DOOSAN	S	H	L	REFRIGERACIÓN	
					INTERNA	EXTERNA
TOED7D50	/	25X25	65	148	X	✓

12

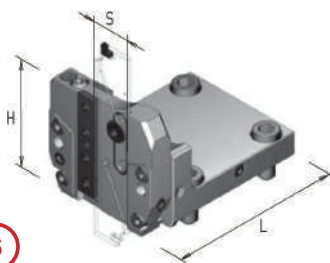
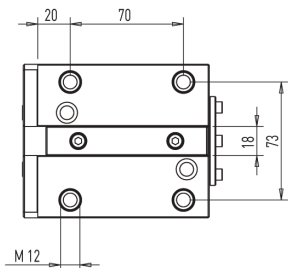

REFERENCIA	DOOSAN	S	H	L	REFRIGERACIÓN	
					INTERNA	EXTERNA
TOED7B32	/	ISCAR 32	78	129	✓	✓

DOOSAN - BMT 55

MODELOS

LYNX 300 (M)
 PUMA 230/240/280 (M,LM,S)
 PUMA 1500/2000/2500 (M,LM,S)
 PUMA 2100 (Y,LY,SY,LSY)
 PUMA GT 2100M
 PUMA H 250TM
 PUMA MX 2100 (ST,LST)
 PUMA TL2000/2500 (M,LM)
 PUMA TT1500/1800 (MS,SY)

MODELOS COMPATIBLES:

SAMSUNG PL 240LM
 HARDINGE T-51/65 SUPER PRECISION-H51
 HYUNDAI WIA L230 LMSA
 SKT-160/180 TTMS/TTSY
 LM1600/1800TTSY
 HWACHEON CUTEX-160/240/T2

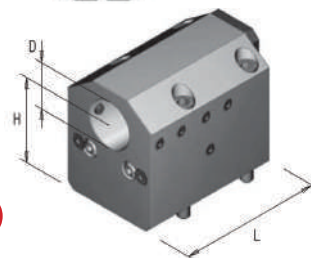
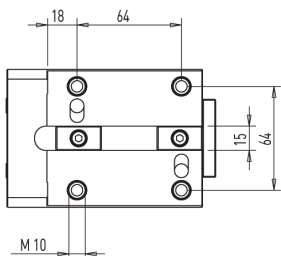
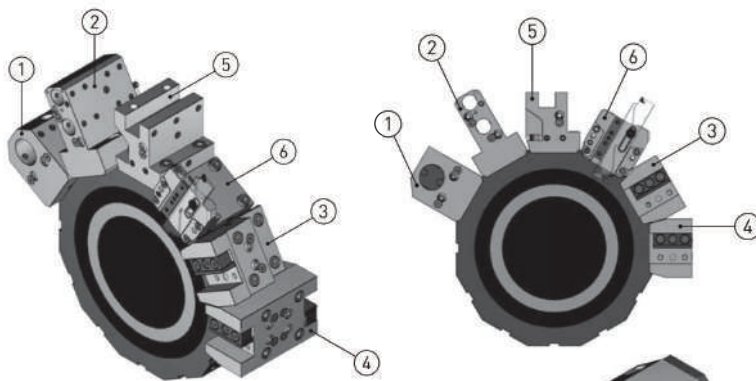

12

REFERENCIA	DOOSAN	D	H	L	REFRIGERACIÓN	
					INTERNA	EXTERNA
TOID6C40	L61590327D	40	70	120	X	✓
TOID6C40R	L61590327D	40	70	120	✓	✓

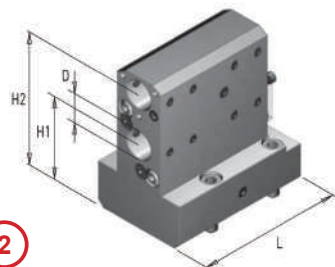
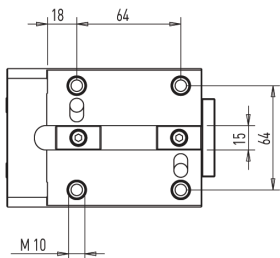

REFERENCIA	DOOSAN	D	H1	H2	L	REFRIGERACIÓN	
						INTERNA	EXTERNA
TOID6D25	L61590357D	25	70	115	126	X	✓
TOID6D25R	L61590357D	25	70	115	126	✓	✓

DOOSAN - BMT 55

MODELOS

LYNX 300 (M)
 PUMA 230/240/280 (M,LM,S)
 PUMA 1500/2000/2500 (M,LM,S)
 PUMA 2100 (Y,LY,SY,LSY)
 PUMA GT 2100M
 PUMA H 250TM
 PUMA MX 2100 (ST,LST)
 PUMA TL2000/2500 (M,LM)
 PUMA TT1500/1800 (MS,SY)

MODELOS COMPATIBLES:

SAMSUNG PL 240LM
 HARDINGE T-51/65 SUPER PRECISION-H51
 HYUNDAI WIA L230 LMSA
 SKT-160/180 TTMS/TTSY
 LM1600/1800TTSY
 HWACHEON CUTEX-160/240/T2

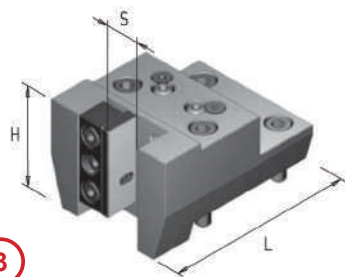
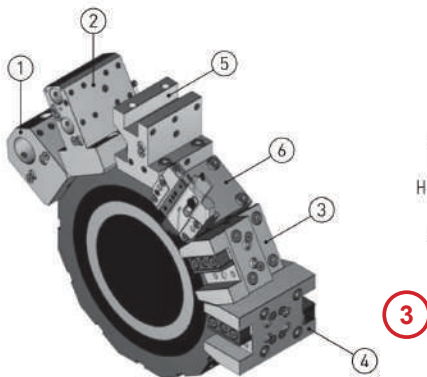
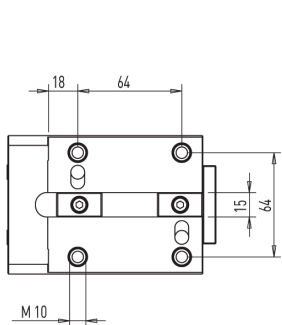

REFERENCIA	DOOSAN	S	H	L	REFRIGERACIÓN	
					INTERNA	EXTERNA
TOED6V50	L31560517B	25X25	60	126	X	✓

12

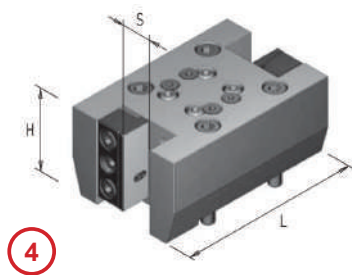
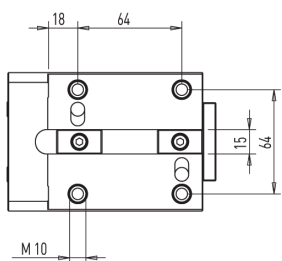

REFERENCIA	DOOSAN	S	H	L	REFRIGERACIÓN	
					INTERNA	EXTERNA
TOED6D50	L61590347A	25X25	65	148	X	✓

DOOSAN - BMT 55

MODELOS

LYNX 300 (M)
 PUMA 230/240/280 (M,LM,S)
 PUMA 1500/2000/2500 (M,LM,S)
 PUMA 2100 (Y,LY,SY,LSY)
 PUMA GT 2100M
 PUMA H 250TM
 PUMA MX 2100 (ST,LST)
 PUMA TL2000/2500 (M,LM)
 PUMA TT1500/1800 (MS,SY)

MODELOS COMPATIBLES:

SAMSUNG PL 240LM
 HARDINGE T-51/65 SUPER PRECISION-H51
 HINDAY WIA L230 LMSA
 SKT-160/180 TTMS/TTSY
 LM1600/1800TTSY
 HWACHEON CUTEX-160/240/T2

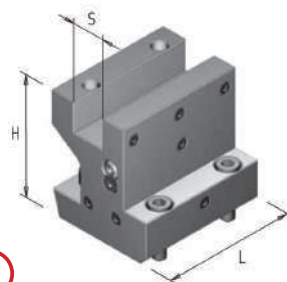
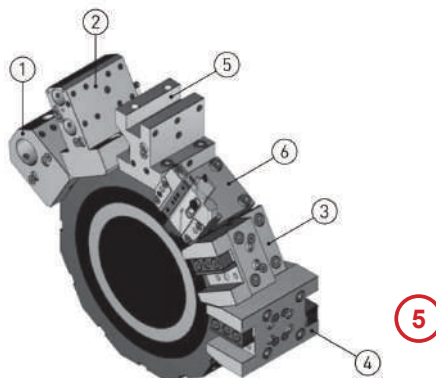
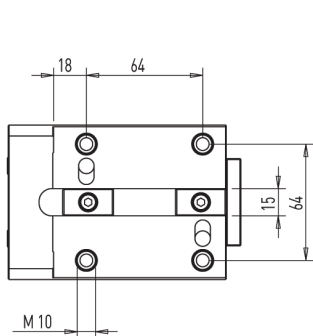

REFERENCIA	DOOSAN	S	H	L	REFRIGERACIÓN	
					INTERNA	EXTERNA
TOED6C25	L31560537C	25X25	95	105	X	✓

12

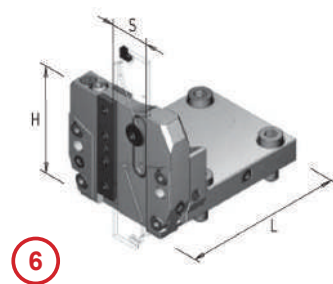
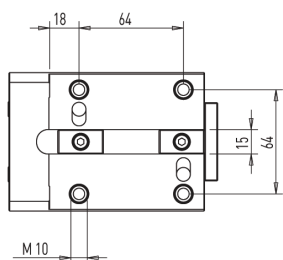

REFERENCIA	DOOSAN	S	H	L	REFRIGERACIÓN	
					INTERNA	EXTERNA
TOED6B32	/	ISCAR32	78	119	✓	✓

DOOSAN - BMT 45

MODELOS

LYNX 220 (M,MSLM)
PUMA MX 1600 (ST)

MODELOS COMPATIBLES:

SAMSUNG PL 1600M/MC
HARDINGE T-42 SUPER PRECISION

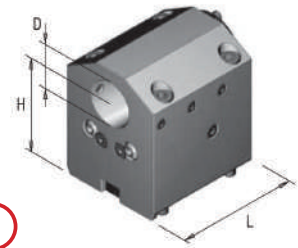
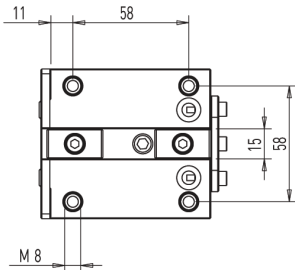
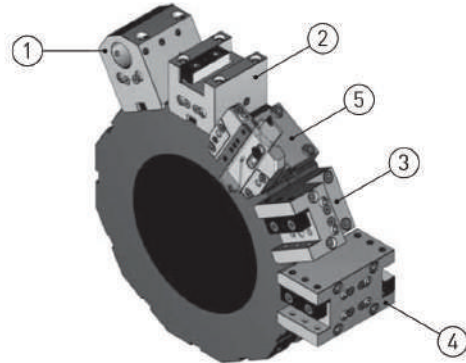

12

REFERENCIA	DOOSAN	D	H	L	REFRIGERACIÓN	
					INTERNA	EXTERNA
TOID5C32H65	/	32	65	85	X	✓
TOID5C32RH65	/	32	65	85	✓	✓

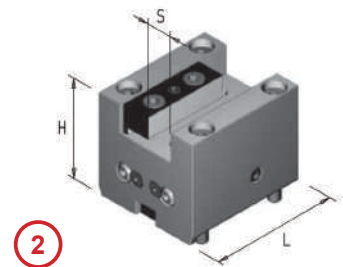
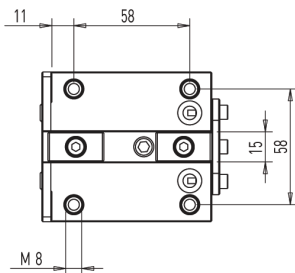

REFERENCIA	DOOSAN	S	H	L	REFRIGERACIÓN	
					INTERNA	EXTERNA
TOED5C40	/	20X20	65	85	X	✓

DOOSAN - BMT 45

MODELOS

LYNX 220 (M,MSLM)
PUMA MX 1600 (ST)

MODELOS COMPATIBLES:

SAMSUNG PL 1600M/MC
HARDINGE T-42 SUPER PRECISION

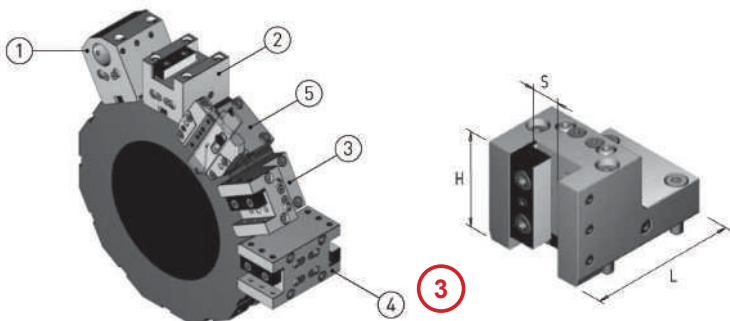
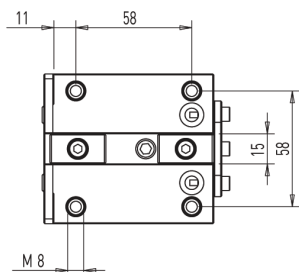

REFERENCIA	DOOSAN	S	H	L	REFRIGERACIÓN	
					INTERNA	EXTERNA
TOED5V40	/	20X20	65	102	X	✓

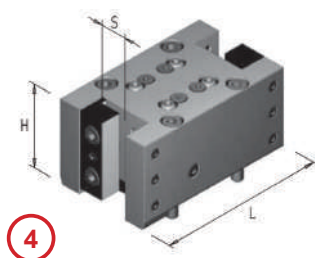
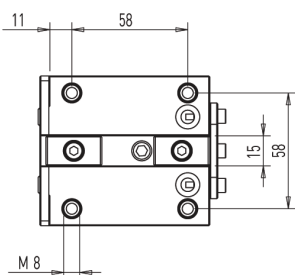

12

REFERENCIA	DOOSAN	S	H	L	REFRIGERACIÓN	
					INTERNA	EXTERNA
TOED5D40	/	20X20	60	124	X	✓

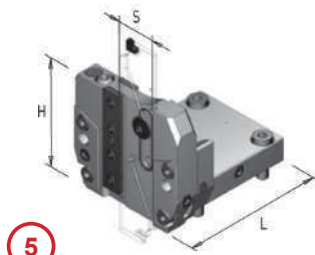
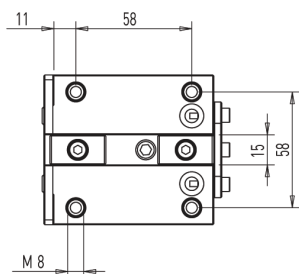

REFERENCIA	DOOSAN	S	H	L	REFRIGERACIÓN	
					INTERNA	EXTERNA
TOED5B32	/	ISCAR32	79	105	✓	✓

BIGLIA

MODELOS

B301-B445-B470-B501 (Y-S) -B510-B545-B550-B565-B650--B658
B1200-B446-B465-B754-B765-B750 (16)-B1250(16)

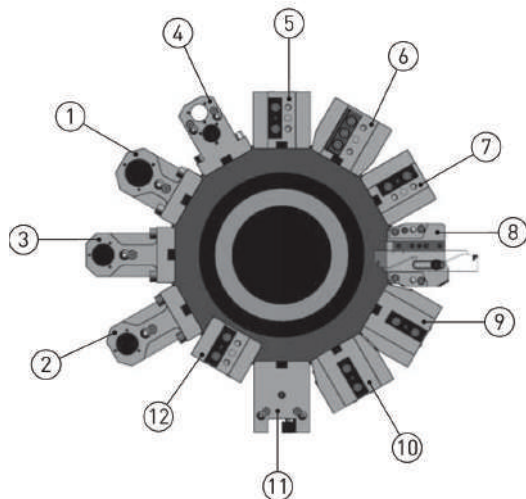
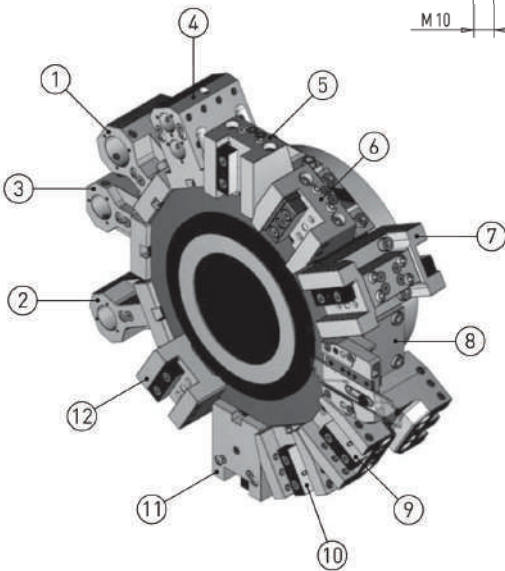
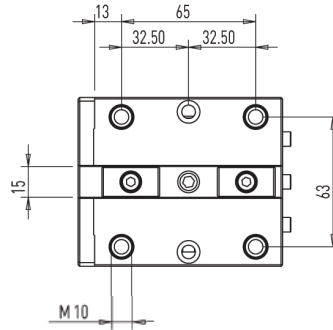

BIGLIA

MODELOS

B301-B445-B470-B501 (Y-S)
 B510-B545-B550-B565-B650
 B658-B1200-B446-B465-B754
 B765-B750 (16)-B1250(16)

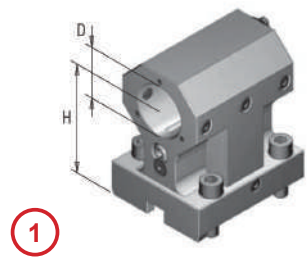
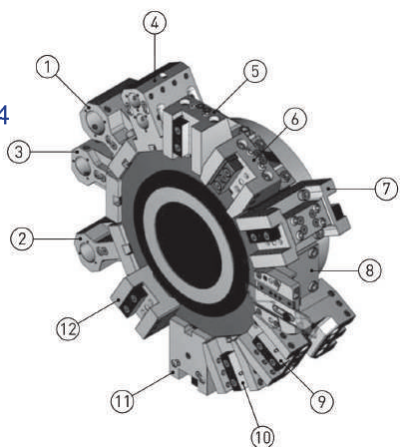
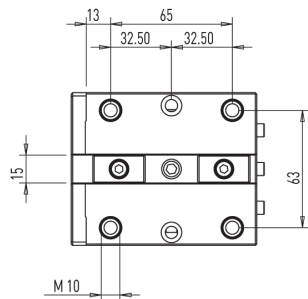

REFERENCIA	BIGLIA	D	H	REFRIGERACIÓN	
				INTERNA	EXTERNA
TOIB6C32	10.57.75.00	32	80	X	✓
TOIB6C32R	10.57.75.00	32	80	✓	✓
TOIB6C40	10.88.15.00	40	80	X	✓
TOIB6C40R	10.88.15.00	40	80	✓	✓

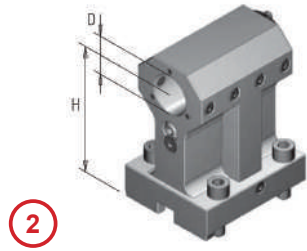
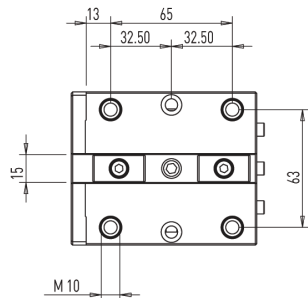

REFERENCIA	BIGLIA	D	H	REFRIGERACIÓN	
				INTERNA	EXTERNA
TOIB6C32H100	10.88.27.00	32	100	X	✓
TOIB6C32RH100	10.88.27.00	32	100	✓	✓

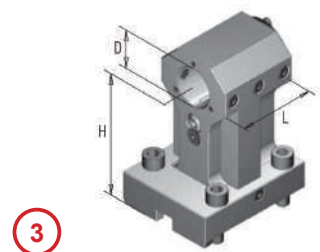
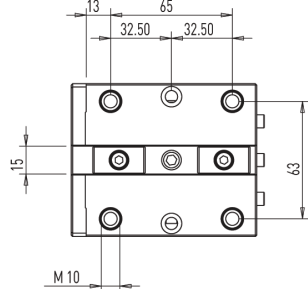

REFERENCIA	BIGLIA	D	H	L	REFRIGERACIÓN	
					INTERNA	EXTERNA
TOIB6A32H100	10.88.28.00	32	100	66	X	✓
TOIB6A32RH100	10.88.28.00	32	100	66	✓	✓

12

BIGLIA

MODELOS

B301-B445-B470-B501 (Y-S)
 B510-B545-B550-B565-B650
 B658-B1200-B446-B465-B754
 B765-B750 (16)-B1250(16)

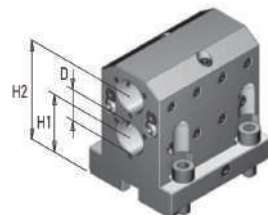
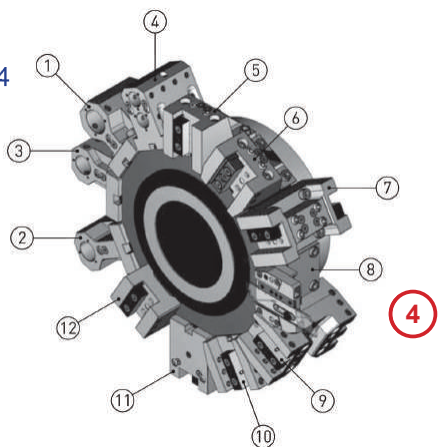
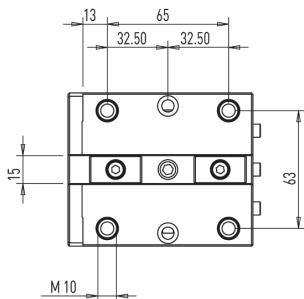

REFERENCIA	BIGLIA	D	H1	H2	REFRIGERACIÓN	
					INTERNA	EXTERNA
TOIB6D25	41.03.29.00	25	45	80	X	✓
TOIB6D25R	41.03.29.00	25	45	80	✓	✓

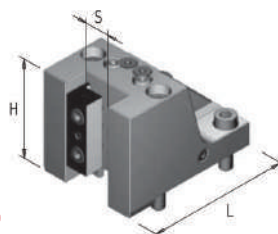
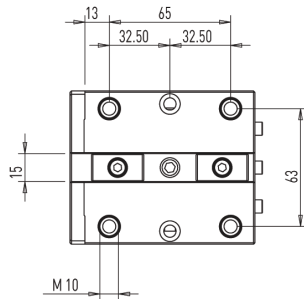

REFERENCIA	BIGLIA	S	H	L	REFRIGERACIÓN	
					INTERNA	EXTERNA
TOEB6V40	10.57.60.00	20X20	79	116	X	✓

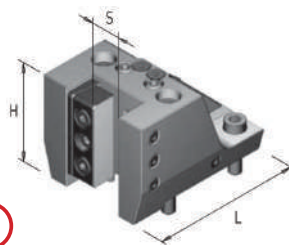
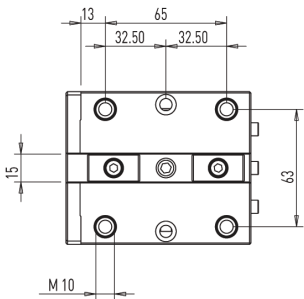

REFERENCIA	BIGLIA	S	H	L	REFRIGERACIÓN	
					INTERNA	EXTERNA
TOEB6V50	10.88.16.00	25X25	79	121	X	✓

12

BIGLIA

MODELOS

B301-B445-B470-B501 (Y-S)
 B510-B545-B550-B565-B650
 B658-B1200-B446-B465-B754
 B765-B750 (16)-B1250(16)

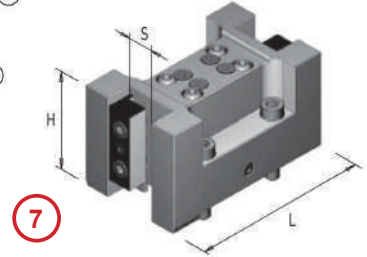
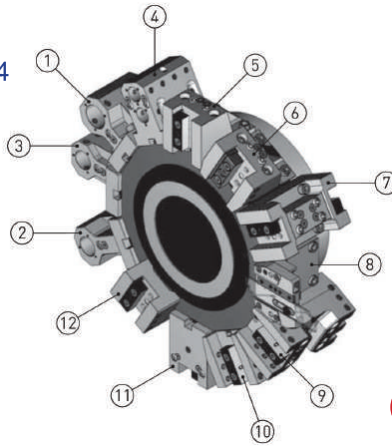
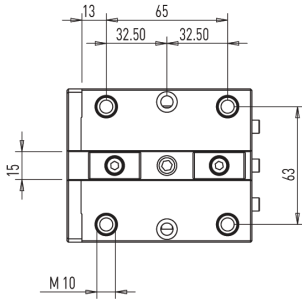

REFERENCIA	BIGLIA	S	H	L	REFRIGERACIÓN	
					INTERNA	EXTERNA
TOEB6D40	10.57.76.00	20X20	76	139	X	✓

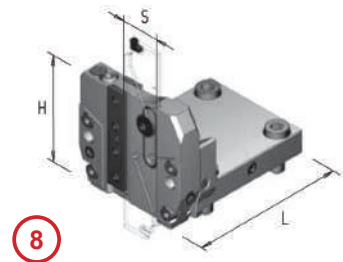
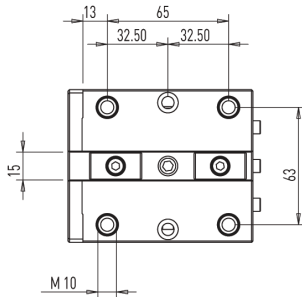

REFERENCIA	BIGLIA	S	H	L	REFRIGERACIÓN	
					INTERNA	EXTERNA
TOEB6B32	/	ISCAR32	79	116	✓	✓

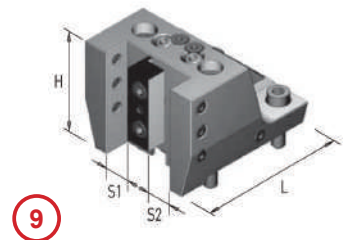
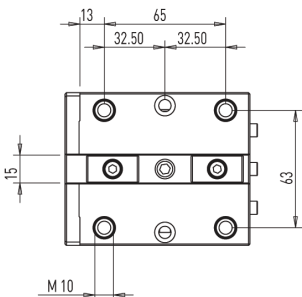

REFERENCIA	BIGLIA	S1	S2	H	L	REFRIGERACIÓN	
						INTERNA	EXTERNA
TOEB6V20D	41.03.25.00	20X20	20X20	79	116	X	✓

BIGLIA

MODELOS

B301-B445-B470-B501 (Y-S)
 B510-B545-B550-B565-B650
 B658-B1200-B446-B465-B754
 B765-B750 (16)-B1250(16)

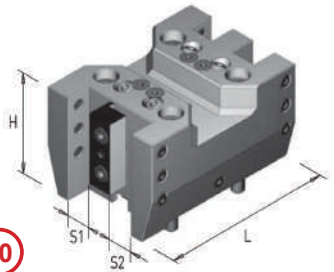
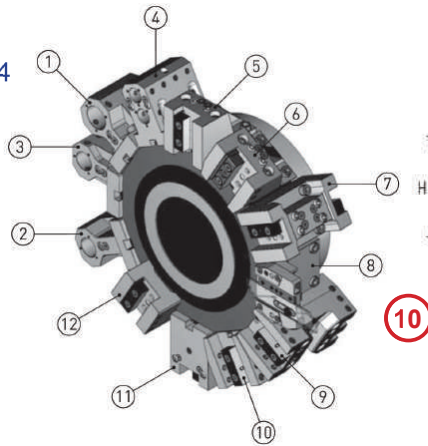
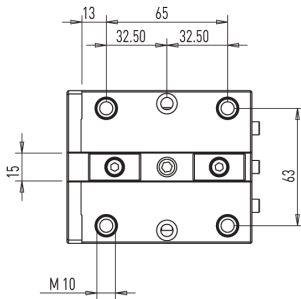

REFERENCIA	BIGLIA	S1	S2	H	L	REFRIGERACIÓN	
						INTERNA	EXTERNA
TOEB6D20Q	/	20X20	20X20	81	140	X	✓

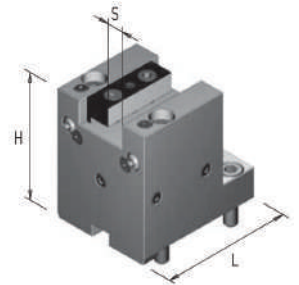
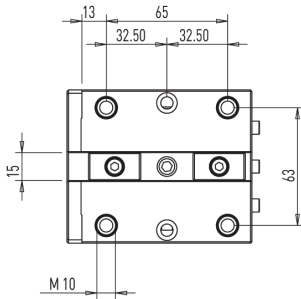

REFERENCIA	BIGLIA	S	H	L	REFRIGERACIÓN	
					INTERNA	EXTERNA
TOEB6C40	41.03.19.00	20X20	100	104	X	✓

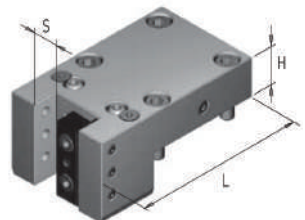
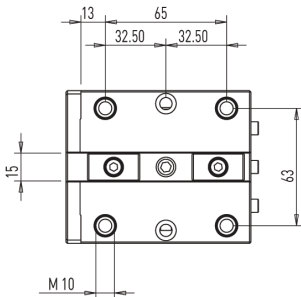

REFERENCIA	BIGLIA	S	H	L	REFRIGERACIÓN	
					INTERNA	EXTERNA
TOEB6V40L	/	20X20	32	40	X	✓

12

BIGLIA
MODELOS
B436 Y2

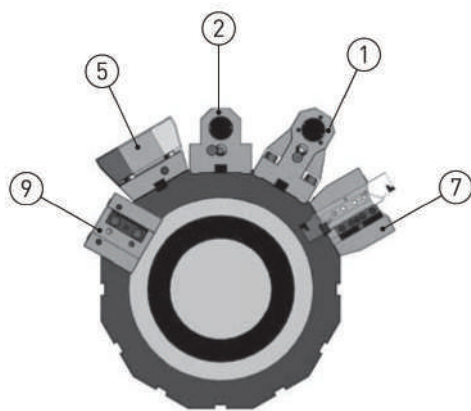
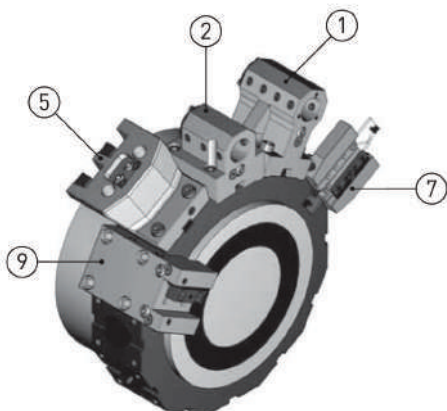
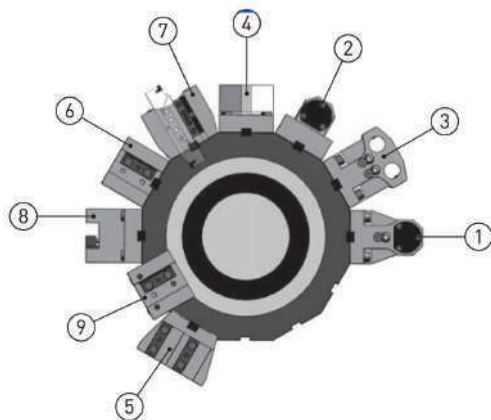
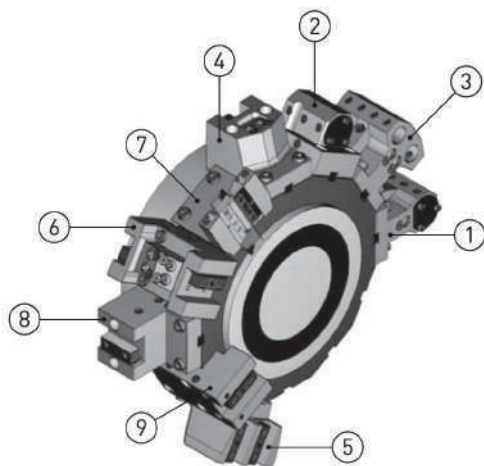
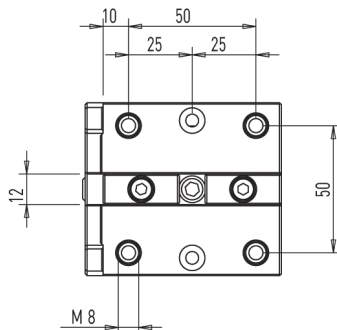

BIGLIA

MODELOS

B436 Y2

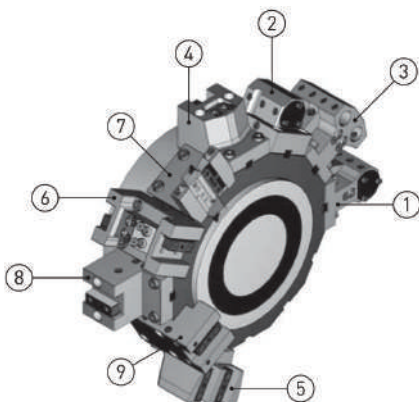
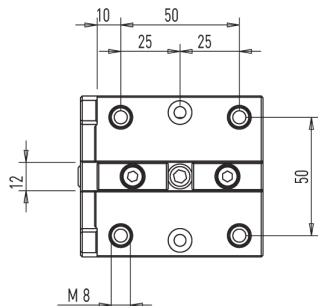

1

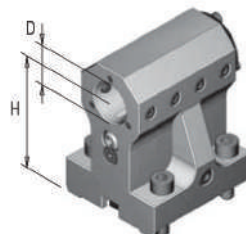

REFERENCIA	BIGLIA	D	H	REFRIGERACIÓN	
				INTERNA	EXTERNA
TOIB4C20H70	0088-00003	20	70	X	✓
TOIB4C20RH70	0088-00003	20	70	✓	✓
TOIB4C25H70	D25.0088-00003	25	70	X	✓
TOIB4C25R H70	D25.0088-00003	25	70	✓	✓

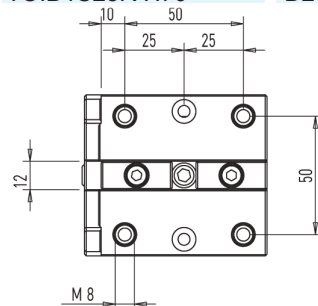

2

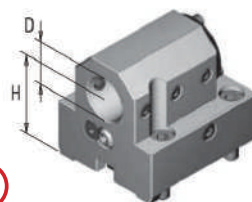

REFERENCIA	BIGLIA	D	H	REFRIGERACIÓN	
				INTERNA	EXTERNA
TOIB4C20H45	0088-00019	20	45	X	✓
TOIB4C20RH45	0088-00019	20	45	✓	✓
TOIB4C25H45	D25.0088-00019	25	45	X	✓
TOIB4C25RH45	D25.0088-00019	25	45	✓	✓

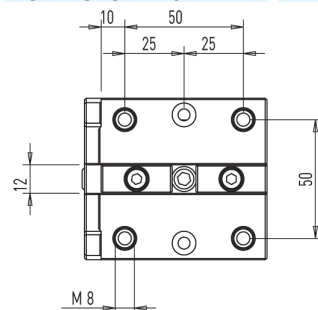

3

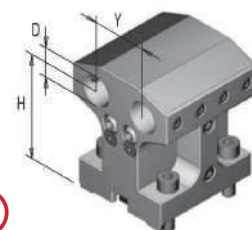

REFERENCIA	BIGLIA	D	H	Y	REFRIGERACIÓN	
					INTERNA	EXTERNA
TOIB4D20Y38	0088-00010	20	70	38	X	✓

BIGLIA
MODELOS
B436 Y2

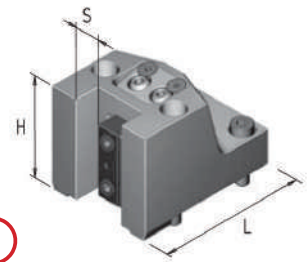
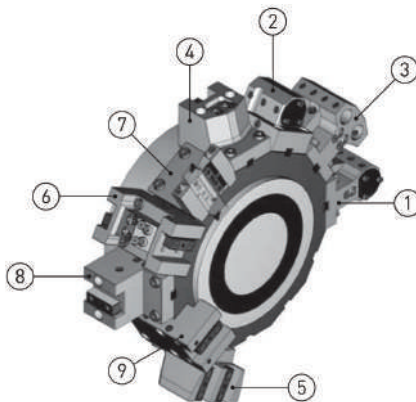
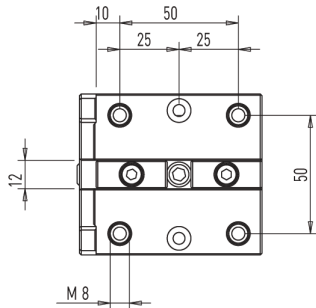

4

REFERENCIA	BIGLIA	S	H	L	REFRIGERACIÓN	
					INTERNA	EXTERNA
TOEB4V32	0088-00004	16X16	60	90	X	✓

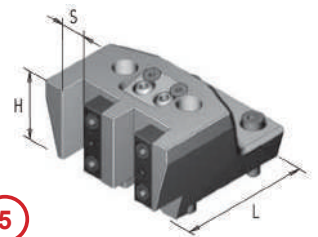
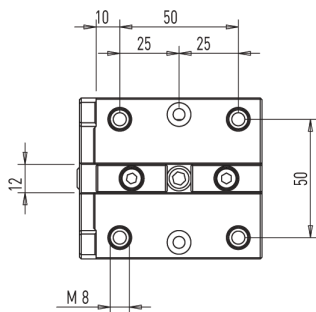

5

REFERENCIA	BIGLIA	S	H	L	REFRIGERACIÓN	
					INTERNA	EXTERNA
TOEB4V16D	0088-00011	16X16	60	100	X	✓

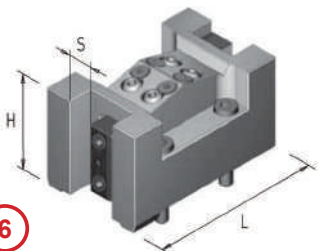
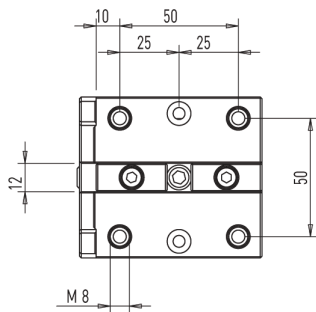

6

REFERENCIA	BIGLIA	S	H	L	REFRIGERACIÓN	
					INTERNA	EXTERNA
TOEB4D32	0088-00005	16X16	60	110	X	✓

BIGLIA

MODELOS

B436 Y2

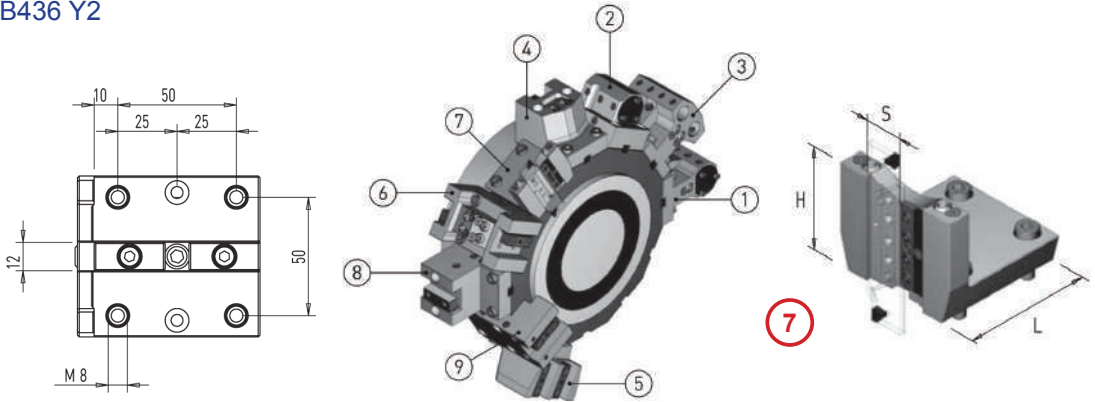

REFERENCIA	BIGLIA	S	H	L	REFRIGERACIÓN	
					INTERNA	EXTERNA
TOEB4B26B	/	ISCAR26	66	82	X	✓



REFERENCIA	BIGLIA	S	H	L	REFRIGERACIÓN	
					INTERNA	EXTERNA
TOEB4C32	0088-00014	16X16	70	85	X	✓



REFERENCIA	BIGLIA	S	H	L	REFRIGERACIÓN	
					INTERNA	EXTERNA
TOEB4V32L	0088-00006	16X16	22	110	X	✓

NAKAMURA - WT 150

MODELOS WT 20II (M,MY)
WT 150/250 TW 10
WTW 150 SUPER NTJ/NTM3
WTS 150 SC 150/250

MODELOS COMPATIBLES:
CMZ TX 52/66

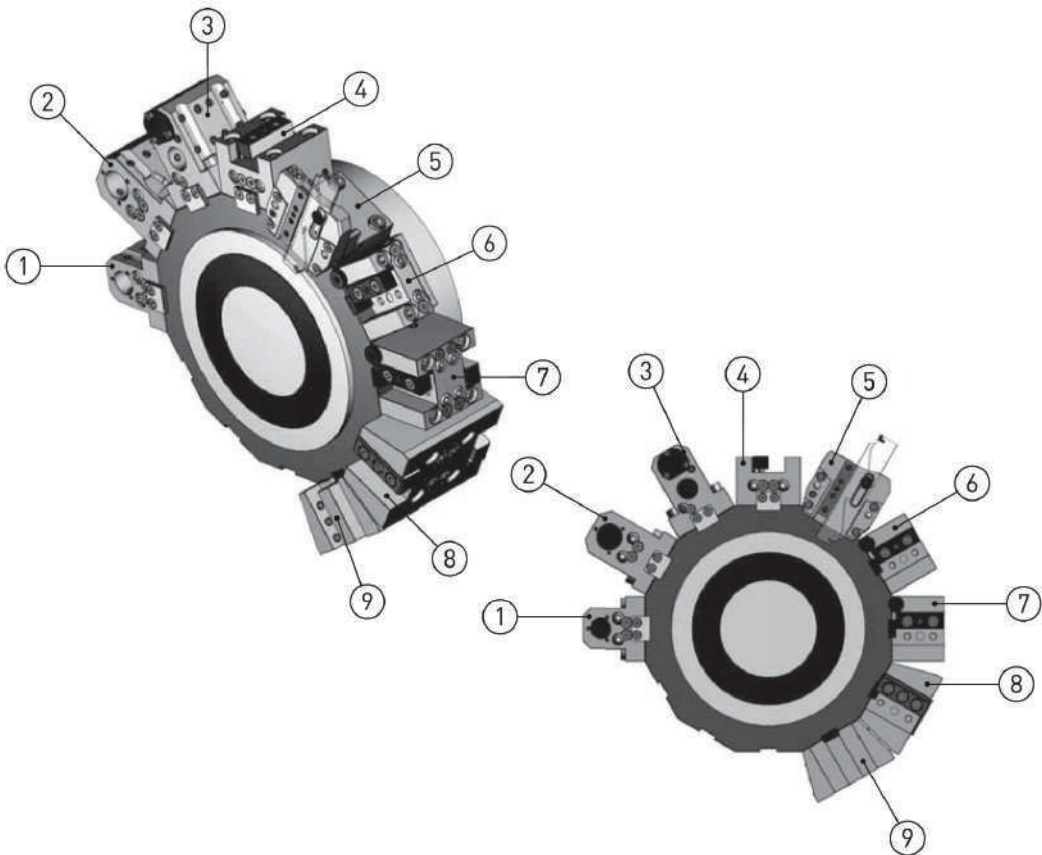
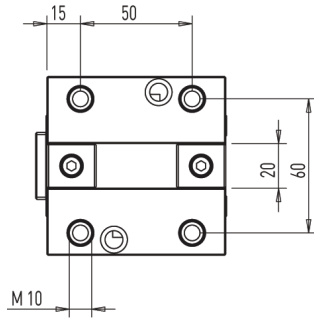

NAKAMURA - WT 150

MODELOS WT 20II (M,MY)
 WT 150/250 TW 10
 WTW 150 SUPER NTJ/NTM3
 WTS 150 SC 150/250

MODELOS COMPATIBLES:
 CMZ TX 52/66

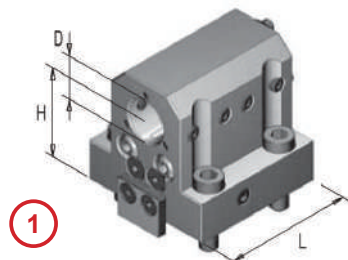
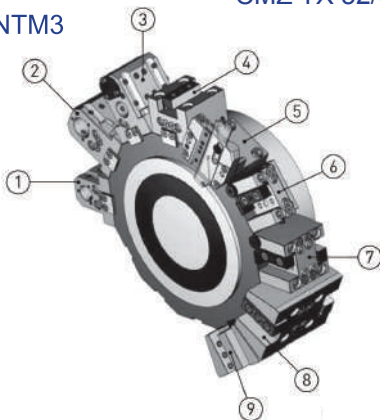
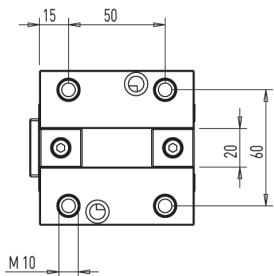

REFERENCIA	NAKAMURA	D	H	L	REFRIGERACIÓN	
					INTERNA	EXTERNA
TOIN4C25H55	/	25	55	80	X	✓
TOIN4C25RH55	/	25	55	80	✓	✓

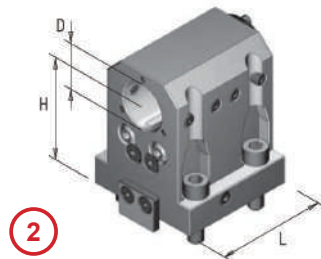
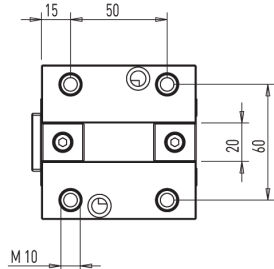

REFERENCIA	NAKAMURA	D	H	L	REFRIGERACIÓN	
					INTERNA	EXTERNA
TOIN4C32H75	/	32	75	80	X	✓
TOIN4C32RH75	/	32	75	80	✓	✓
TOIN4C40H75	/	40	75	80	X	✓
TOIN4C40RH75	/	40	75	80	✓	✓

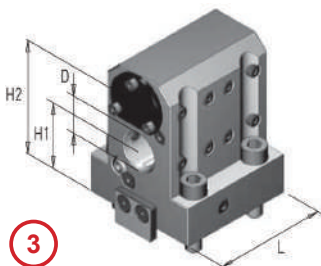
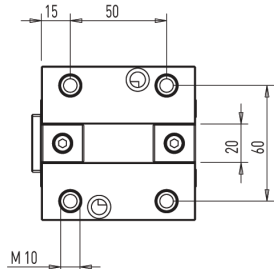

REFERENCIA	NAKAMURA	D	H1	H	L	REFRIGERACIÓN	
						INTERNA	EXTERNA
TOIN4D25	/	25	47.5	82.5	80	X	✓
TOIN4D25R	/	25	47.5	82.5	80	✓	✓

NAKAMURA - WT 150

MODELOS WT 20II (M,MY)
 WT 150/250 TW 10
 WTW 150 SUPER NTJ/NTM3
 WTS 150 SC 150/250

MODELOS COMPATIBLES:
 CMZ TX 52/66

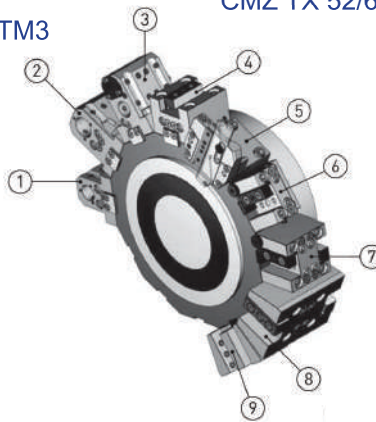
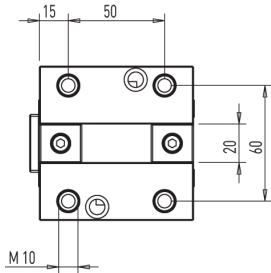

4

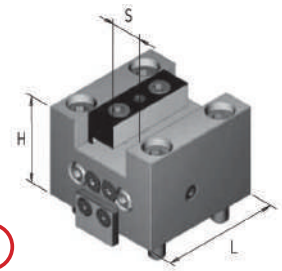

REFERENCIA	NAKAMURA	S	H	L	REFRIGERACIÓN	
					INTERNA	EXTERNA
TOEN4C40	/	20X20	60	80	X	✓

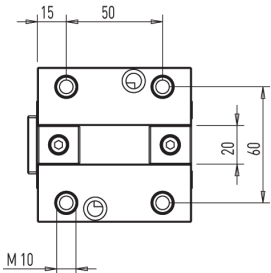

5

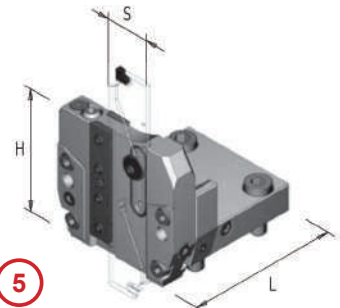

REFERENCIA	NAKAMURA	S	H	L	REFRIGERACIÓN	
					INTERNA	EXTERNA
TOEN4B32	/	ISCAR32	78	99	✓	✓

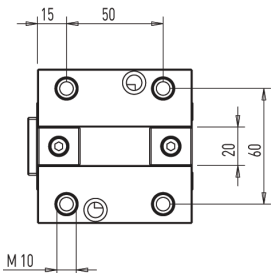

6

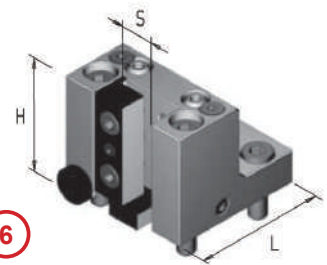

REFERENCIA	NAKAMURA	S	H	L	REFRIGERACIÓN	
					INTERNA	EXTERNA
TOEN4V40	/	20X20	65	80	X	✓

NAKAMURA - WT 150

MODELOS WT 20II (M,MY)
 WT 150/250 TW 10
 WTW 150 SUPER NTJ/NTM3
 WTS 150 SC 150/250

MODELOS COMPATIBLES:
 CMZ TX 52/66

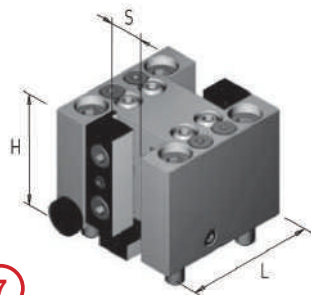
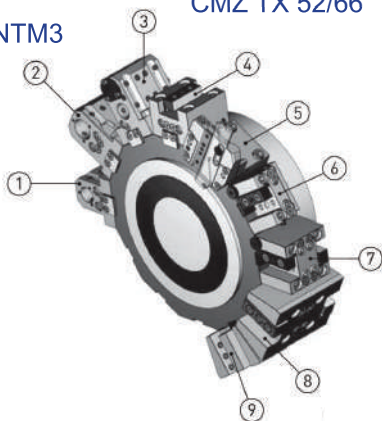
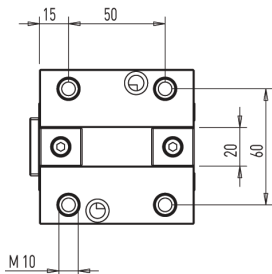

7

REFERENCIA	NAKAMURA	S	H	L	REFRIGERACIÓN	
					INTERNA	EXTERNA
TOEN4D40	/	20X20	65	80	X	✓

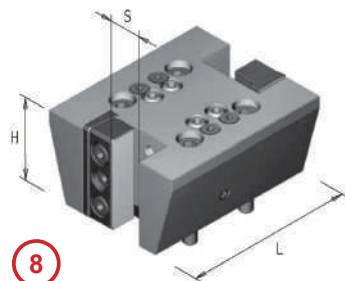
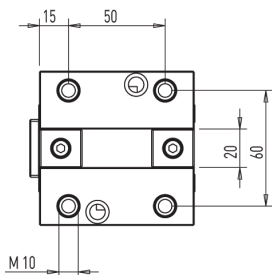

8

REFERENCIA	NAKAMURA	S	H	L	REFRIGERACIÓN	
					INTERNA	EXTERNA
TOEN4D50	/	25X25	65	132	X	✓

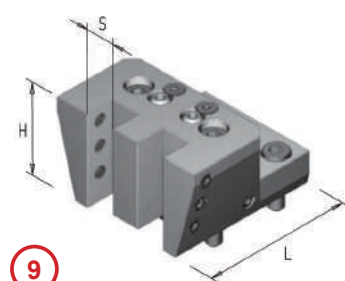
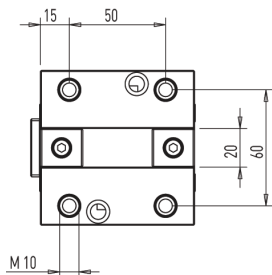

9

REFERENCIA	NAKAMURA	S	H	L	REFRIGERACIÓN	
					INTERNA	EXTERNA
TOEN4V20D	/	20X20	65	106	X	✓

NAKAMURA - WT 100

MODELOS

WT 100 - WY 100

NTY 3 - NTJ100

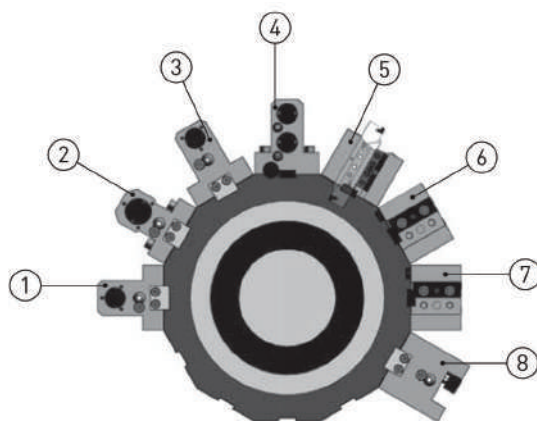
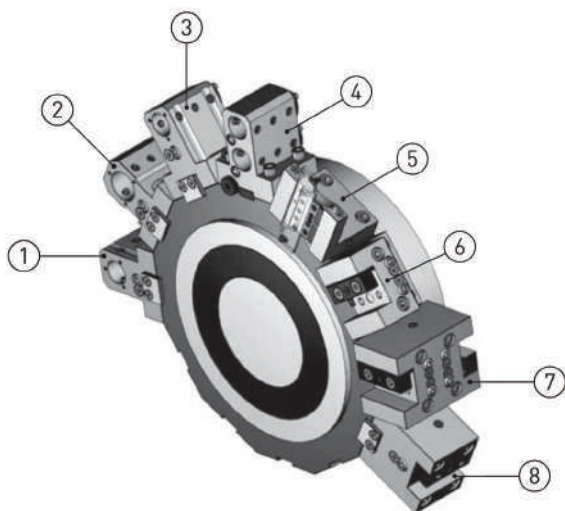
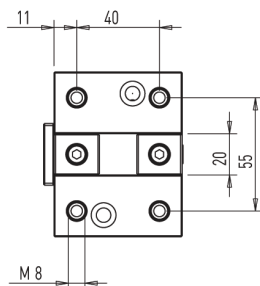

NAKAMURA - WT 100

MODELOS

WT 100 - WY 100

NTY 3 - NTJ100

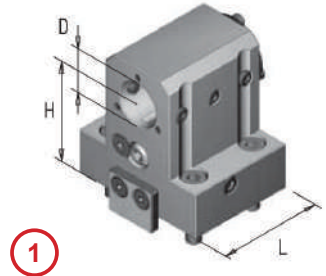
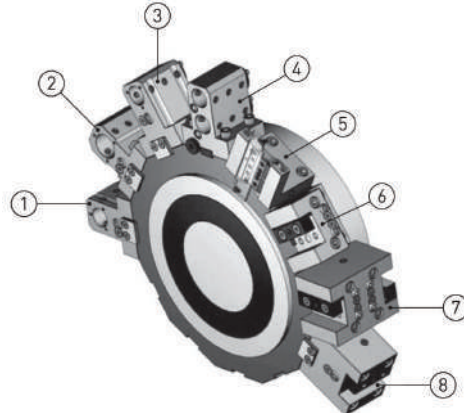
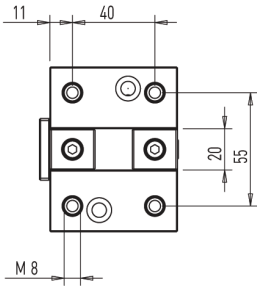

REFERENCIA	NAKAMURA	D	H	L	REFRIGERACIÓN	
					INTERNA	EXTERNA
TOIN3C25H60	/	25	60	62	X	✓
TOIN3C25RH60	/	25	60	62	✓	✓

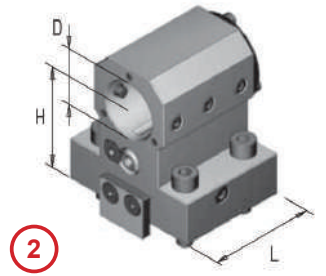
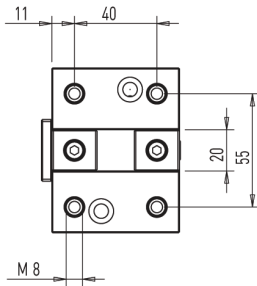

REFERENCIA	NAKAMURA	D	H	L	REFRIGERACIÓN	
					INTERNA	EXTERNA
TOIN3C32H60	/	32	60	62	X	✓
TOIN3C32RH60	/	32	60	62	✓	✓

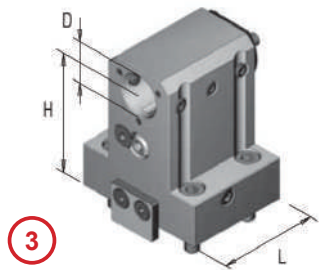
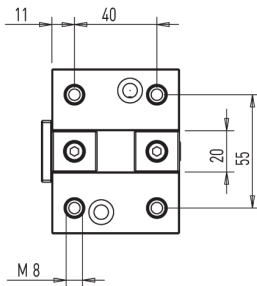

REFERENCIA	NAKAMURA	D	H	L	REFRIGERACIÓN	
					INTERNA	EXTERNA
TOIN3C25H75	/	25	75	62	X	✓
TOIN3C25RH75	/	25	75	62	✓	✓

NAKAMURA - WT 100

MODELOS

WT 100 - WY 100

NTY 3 - NTJ100

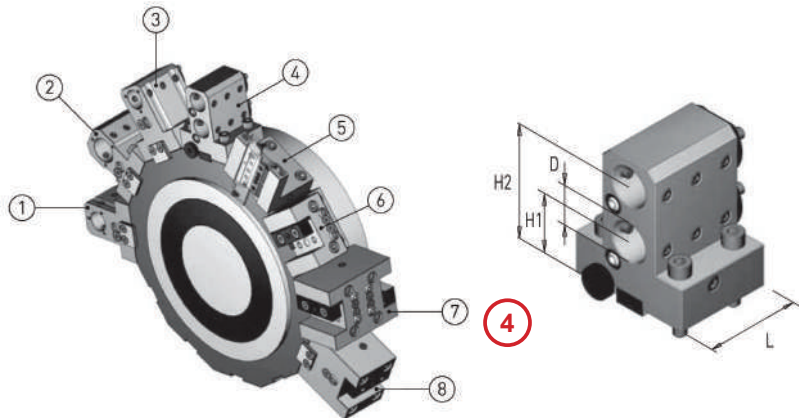
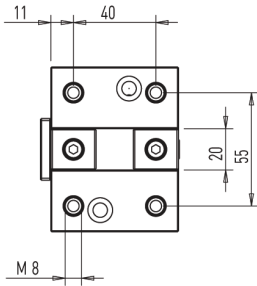

REFERENCIA	NAKAMURA	D	H1	H2	L	REFRIGERACIÓN	
						INTERNA	EXTERNA
TOIN3D25	/	25	39	75	62	✓	✓

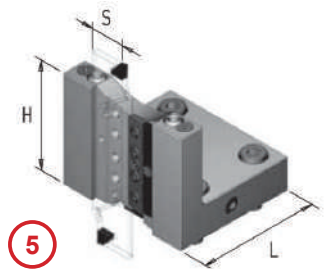
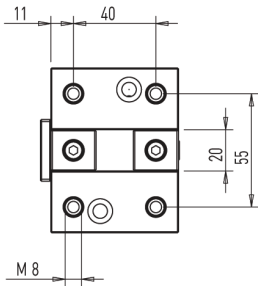

REFERENCIA	NAKAMURA	D	H	L	REFRIGERACIÓN	
					INTERNA	EXTERNA
TOEN3B26B	/	ISCAR26	66	73	X	✓

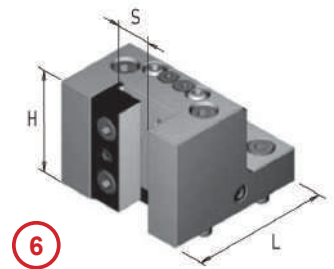
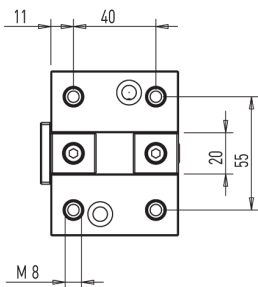

REFERENCIA	NAKAMURA	S	H	L	REFRIGERACIÓN	
					INTERNA	EXTERNA
TOEN3V40	/	20X20	62	83	X	✓

NAKAMURA - WT 100

MODELOS

WT 100 - WY 100

NTY 3 - NTJ100

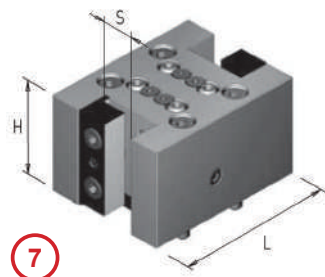
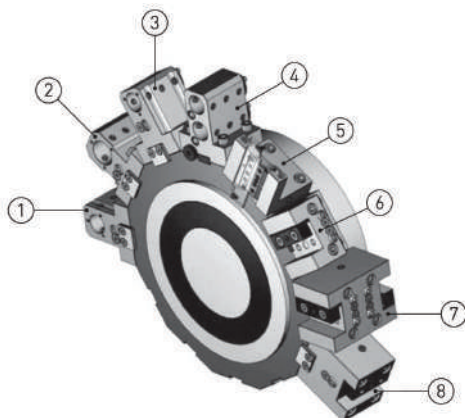
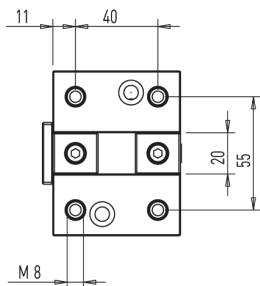

REFERENCIA	NAKAMURA	S	H	L	REFRIGERACIÓN	
					INTERNA	EXTERNA
TOEN3D40	/	20X20	62	104	X	✓

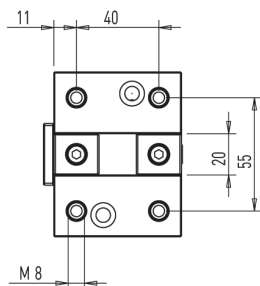

12

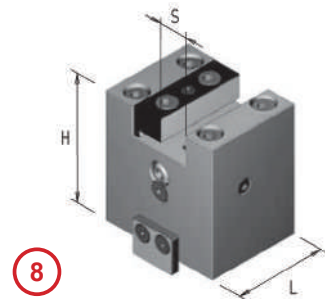

REFERENCIA	NAKAMURA	S	H	L	REFRIGERACIÓN	
					INTERNA	EXTERNA
TOEN3C40	/	20X20	85	62	X	✓



CMZ

MODELOS

TBI 520
TL 20/25
TC 15/20/25/30/35

MODELOS

TA15M/Y/MS/MY/YS - TA 20M/Y/MS/MY/YS
TA 25M/Y/MS/MY/YS - TA 30M/Y/MS/MY/YS

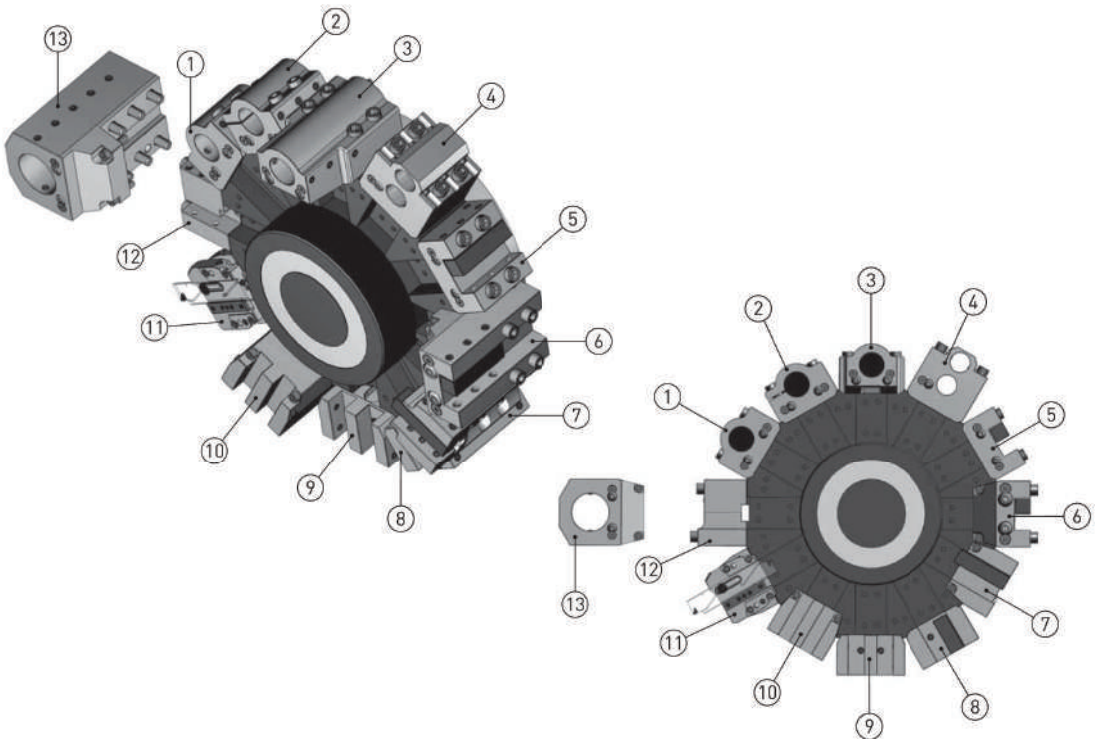
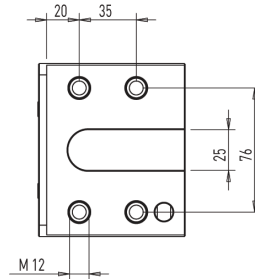

CMZ

MODELOS

TBI 520
TL 20/25
TC 15/20/25/30/35

MODELOS

TA15M/Y/MS/MY/YS - TA 20M/Y/MS/MY/YS
TA 25M/Y/MS/MY/YS - TA 30M/Y/MS/MY/YS

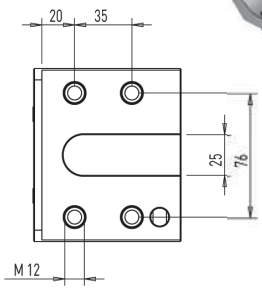
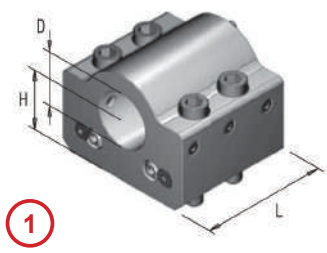
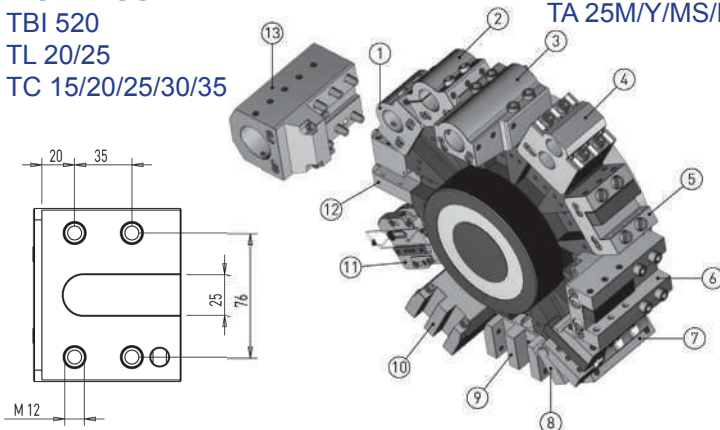

REFERENCIA	CMZ	D	H	L	REFRIGERACIÓN	
					INTERNA	EXTERNA
TOIC6C40	TL20/10000/09	40	40	90	X	✓
TOIC6C40R	TL20/10000/12	40	40	90	✓	✓
TOIC6C50	TL20/10000/40	50	40	90	X	✓
TOIC6C50R	TL20/10000/40	50	40	90	✓	✓

12

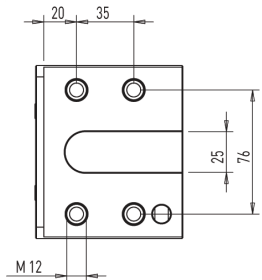
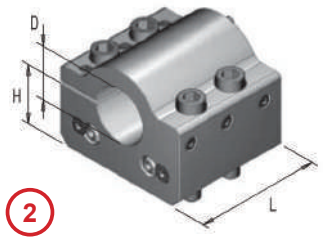

REFERENCIA	CMZ	D	H	L	REFRIGERACIÓN	
					INTERNA	EXTERNA
TOIC6C40B	/	40	40	90	X	✓

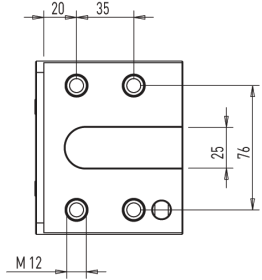
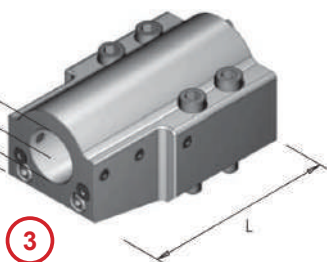

REFERENCIA	CMZ	D	H	L	REFRIGERACIÓN	
					INTERNA	EXTERNA
TOIC6L40	TL20/10000/10	40	40	160	X	✓
TOIC6L40R	TL20/10000/10	40	40	160	✓	✓
TOIC6L50	TL20/10000/39	50	40	160	X	✓
TOIC6L50R	TL20/10000/39	50	40	160	✓	✓

CMZ

MODELOS

TBI 520
TL 20/25
TC 15/20/25/30/35

MODELOS

TA15M/Y/MS/MY/YS - TA 20M/Y/MS/MY/YS
TA 25M/Y/MS/MY/YS - TA 30M/Y/MS/MY/YS

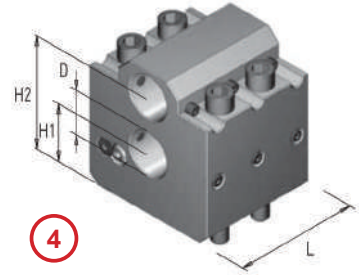
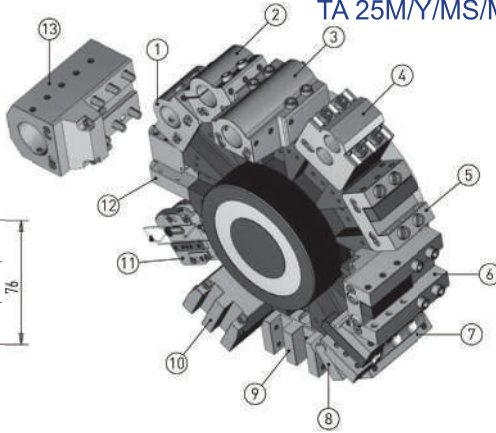
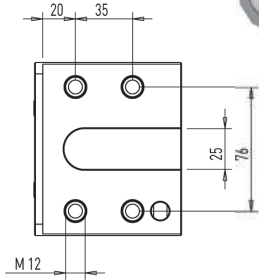

4

REFERENCIA	CMZ	D	H1	H2	L	REFRIGERACIÓN	
						INTERNA	EXTERNA
TOIC6D32	TL20/10000/11	32	40	82	88	X	✓

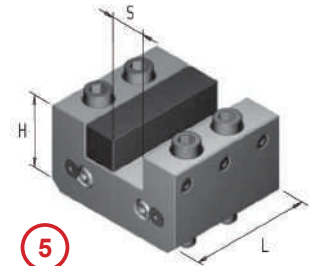
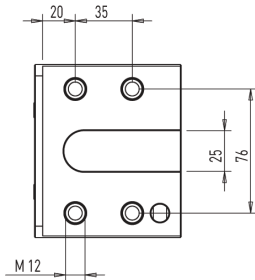

5

REFERENCIA	CMZ	S	H	L	REFRIGERACIÓN	
					INTERNA	EXTERNA
TOEC6C50	TL20/10000/08	25X25	50	90	X	✓
TOEC6L50	/	25X25	60	160	X	✓

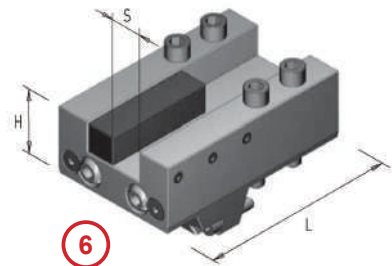
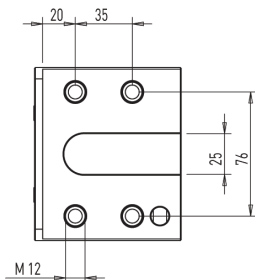

6

REFERENCIA	CMZ	S	H	L	REFRIGERACIÓN	
					INTERNA	EXTERNA
TOEC8L50	TC35/10000/57	25X25	55	165	X	✓

CMZ

MODELOS

TBI 520
TL 20/25
TC 15/20/25/30/35

MODELOS

TA15M/Y/MS/MY/YS - TA 20M/Y/MS/MY/YS
TA 25M/Y/MS/MY/YS - TA 30M/Y/MS/MY/YS

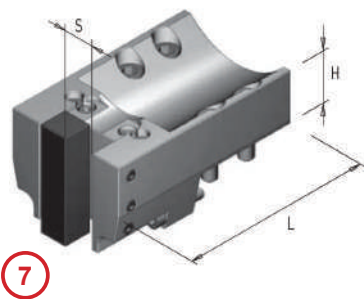
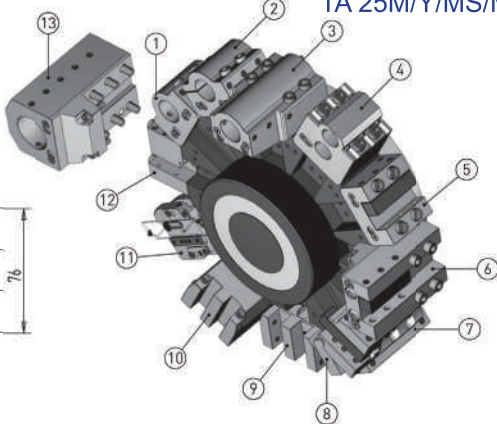
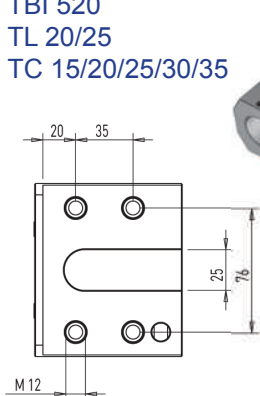

REFERENCIA	CMZ	S	H	L	REFRIGERACIÓN	
					INTERNA	EXTERNA
TOEC6V50	TL20/10000/06	25X25	44	130	X	✓
TOEC6V50L	TL20/10000/45	25X25	44	165	X	✓

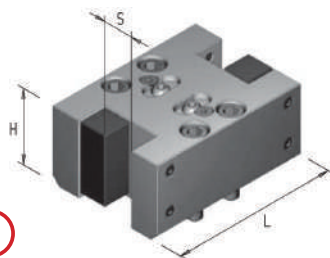
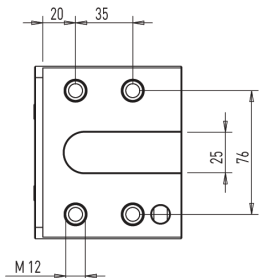

REFERENCIA	CMZ	S	H	L	REFRIGERACIÓN	
					INTERNA	EXTERNA
TOEC6D50	TL20/10000/07	25X25	60	139	X	✓

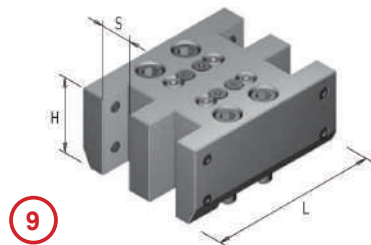
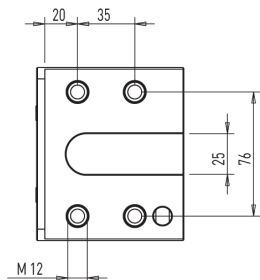

REFERENCIA	CMZ	S	H	L	REFRIGERACIÓN	
					INTERNA	EXTERNA
TOEC6D20Q	/	20X20	60	139	X	✓
TOEC6D25Q	/	25X25	60	139	X	✓

CMZ

MODELOS

TBI 520
TL 20/25
TC 15/20/25/30/35

MODELOS

TA 15M/Y/MS/MY/YS - TA 20M/Y/MS/MY/YS
TA 25M/Y/MS/MY/YS - TA 30M/Y/MS/MY/YS

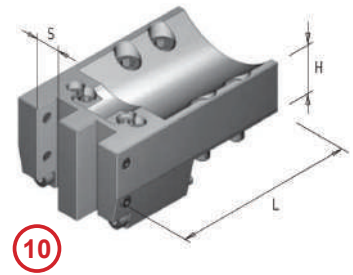
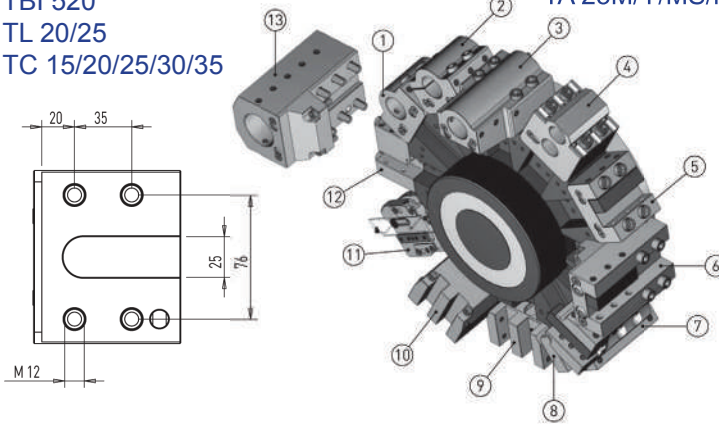

REFERENCIA	CMZ	S	H	L	REFRIGERACIÓN	
					INTERNA	EXTERNA
TOEC6V20D	/	20X20	44	165	X	✓

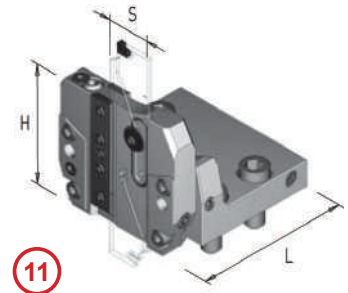
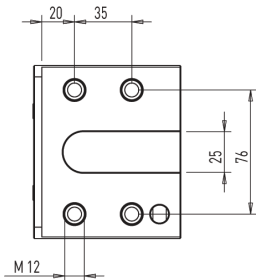

REFERENCIA	CMZ	S	H	L	REFRIGERACIÓN	
					INTERNA	EXTERNA
TOEC6B32	TL20/10000/44	ISCAR32	80	103	✓	✓

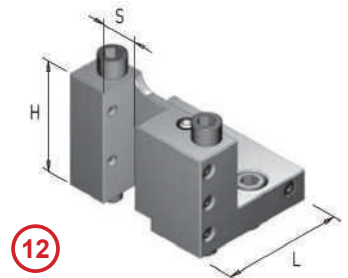
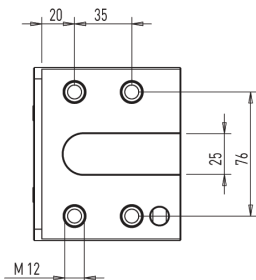

REFERENCIA	CMZ	S	H	L	REFRIGERACIÓN	
					INTERNA	EXTERNA
TOEC6B25	TL20/10000/13	25X25	78	85	X	✓

12

CMZ

MODELOS

TBI 520
 TL 20/25
 TC 15/20/25/30/35

MODELOS

TA15M/Y/MS/MY/YS - TA 20M/Y/MS/MY/YS
 TA 25M/Y/MS/MY/YS - TA 30M/Y/MS/MY/YS

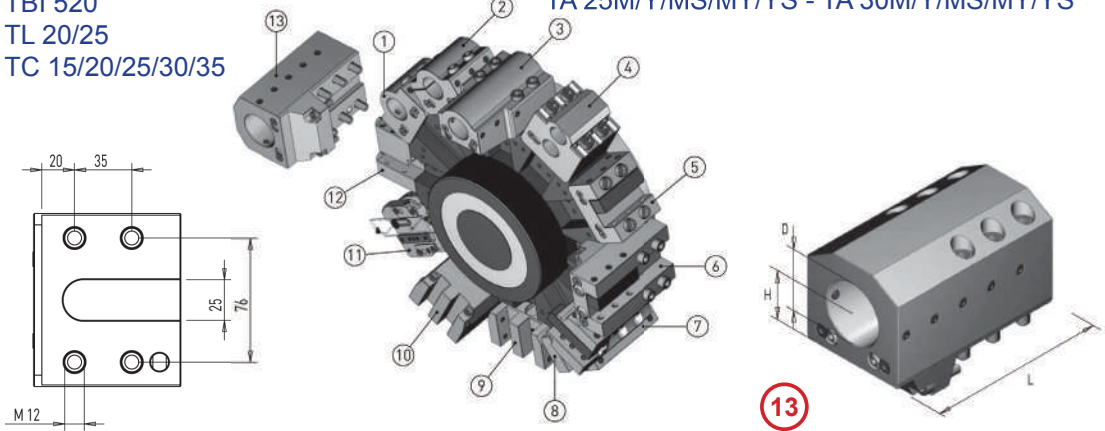

REFERENCIA	CMZ	D	H	L	REFRIGERACIÓN	
					INTERNA	EXTERNA
TOIC8L60	T35/10000/54	60	50	180	✓	✓



CMZ

MODELOS

TL 15T/M/TM/S/MS
TB46/67 M/CM

MODELOS COMPATIBLES:

MIYANO ABX 51/64 THY/SYY

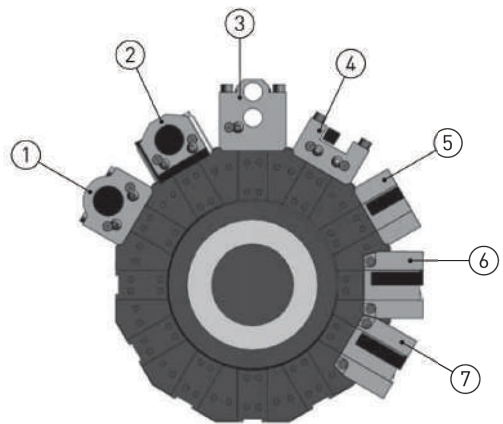
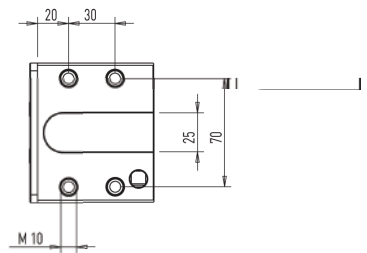
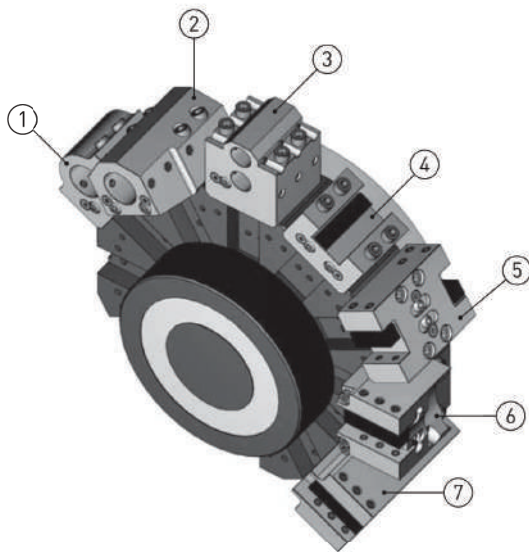

12

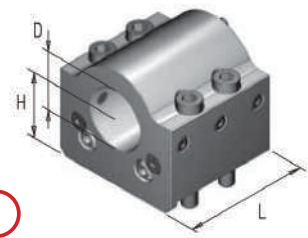
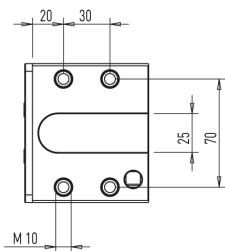

REFERENCIA	CMZ	D	H	L	REFRIGERACIÓN	
					INTERNA	EXTERNA
TOIC3C40	TL15/10000/09	40	40	80	X	✓
TOIC3C40R	TL15/10000/12	40	40	80	✓	✓

CMZ

MODELOS

TL 15T/M/TM/S/MS
TB46/67 M/CM

MODELOS COMPATIBLES:

MIYANO ABX 51/64 THY/SYY

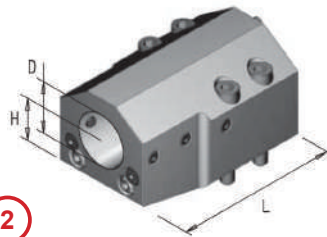
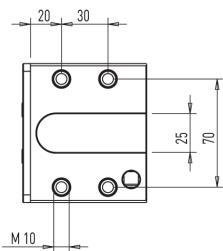
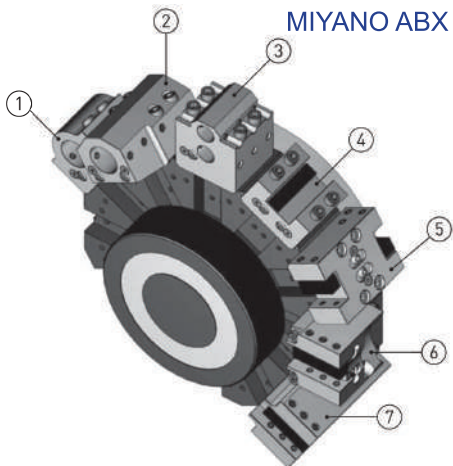

2

REFERENCIA	CMZ	D	H	L	REFRIGERACIÓN	
					INTERNA	EXTERNA
TOIC3L40	TL15/10000/38	40	40	135	X	✓
TOIC3L40R	TL15/10000/38	40	40	135	✓	✓

12

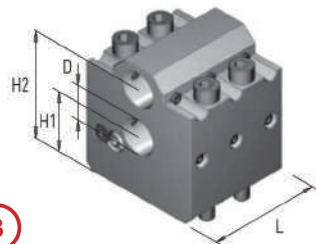
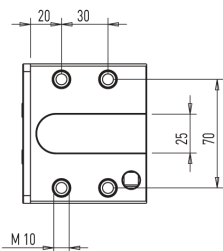

3

REFERENCIA	CMZ	D	H1	H2	L	REFRIGERACIÓN	
						INTERNA	EXTERNA
TOIC3D25	TL15/10000/11	25	40	75	79	X	✓

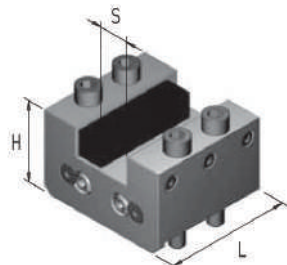
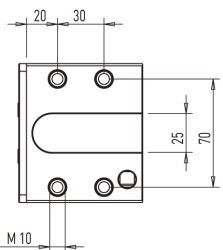

4

REFERENCIA	CMZ	S	H	L	REFRIGERACIÓN	
					INTERNA	EXTERNA
TOEC3C40	TL15/10000/08	20x20	50	80	X	✓

CMZ

MODELOS

TL 15T/M/TM/S/MS
TB46/67 M/CM

MODELOS COMPATIBLES:

MIYANO ABX 51/64 THY/SYY

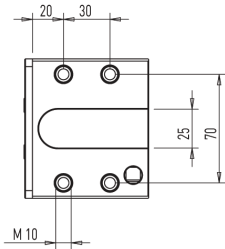
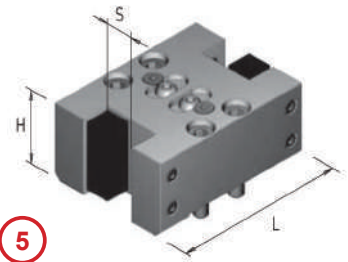
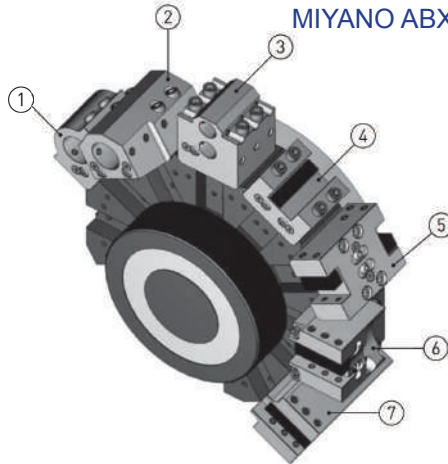

REFERENCIA	CMZ	S	H	L	REFRIGERACIÓN	
					INTERNA	EXTERNA
TOEC3D40	TL15/10000/07	20X20	50	120	X	✓

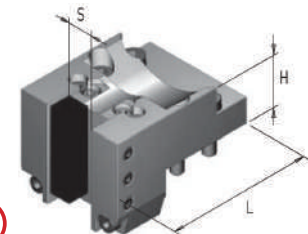
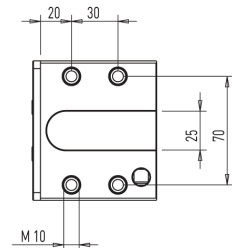

REFERENCIA	CMZ	S	H	L	REFRIGERACIÓN	
					INTERNA	EXTERNA
TOEC3T40	TL15/10000/06	20X20	44	120	X	✓

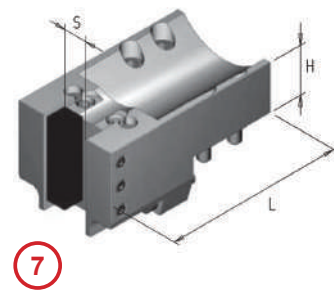
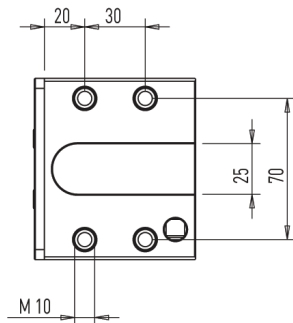

REFERENCIA	CMZ	S	H	L	REFRIGERACIÓN	
					INTERNA	EXTERNA
TOEC3V40	TL15/10000/45	20x20	44	155	X	✓

HAAS

MODELOS

SL20/SL30
ST20/ST25/ST30

MODELOS COMPATIBLES:

OKUMA LB15/25/300

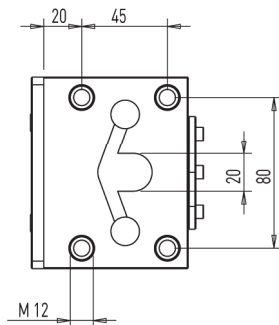

12

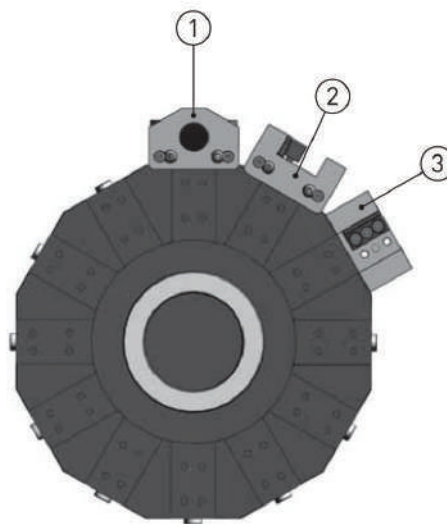
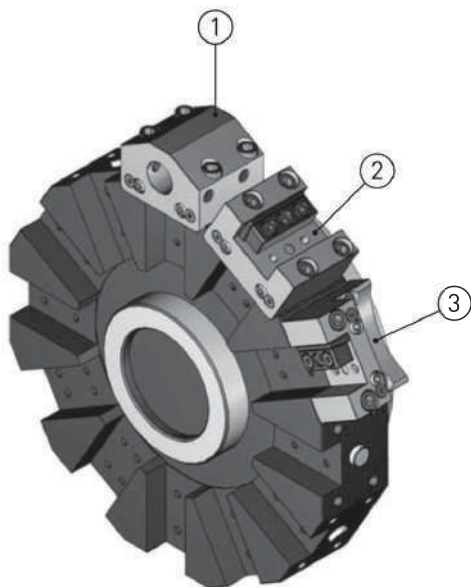

HAAS

MODELOS

SL20/SL30

ST20/ST25/ST30

MODELOS COMPATIBLES:

OKUMA LB15/25/300

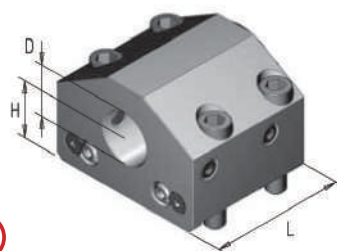
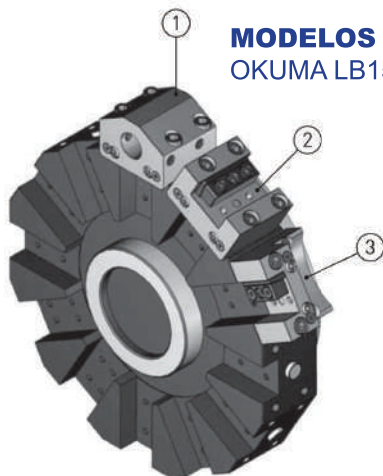
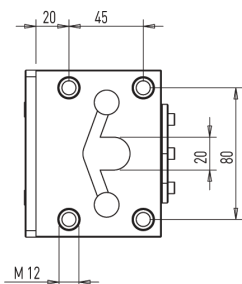

1

REFERENCIA	HASS	D	H	L	REFRIGERACIÓN	
					INTERNA	EXTERNA
TOIH6C32	BOT20MID	32	31.75	101.5	X	✓
TOIH6C32R	BOT20MID	32	31.75	101.5	✓	✓
TOIH6C40	BOT20MID	40	31.75	101.5	X	✓
TOIH6C40R	BOT20MID	40	31.75	101.5	✓	✓

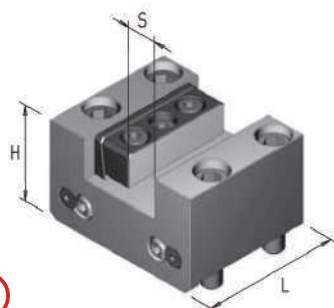
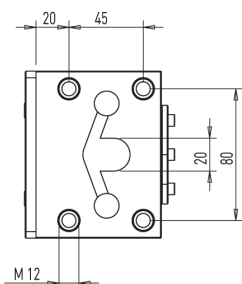

2

REFERENCIA	HASS	S	H	L	REFRIGERACIÓN	
					INTERNA	EXTERNA
TOEH6C50	BOT20MFG	25X25	56	101.5	X	✓

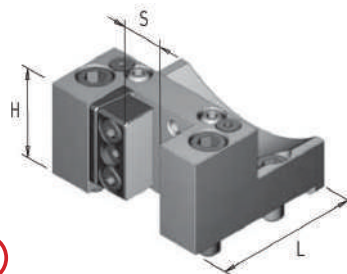
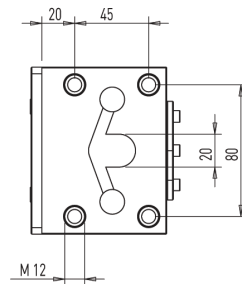

3

REFERENCIA	HASS	S	H	L	REFRIGERACIÓN	
					INTERNA	EXTERNA
TOEH6V50	BOT20MOD	25X25	55	91.5	X	✓

HAAS

MODELOS

SL10
ST10/ST15

MODELOS COMPATIBLES:

OKUMA LLC 152 S

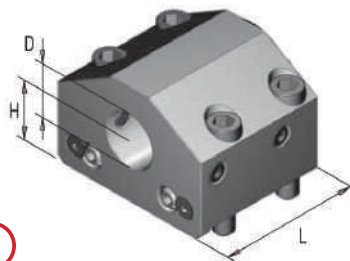
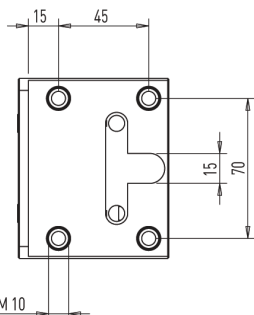
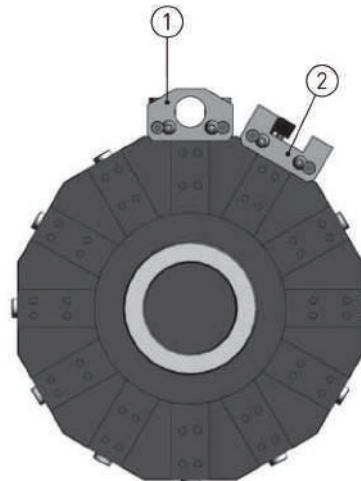
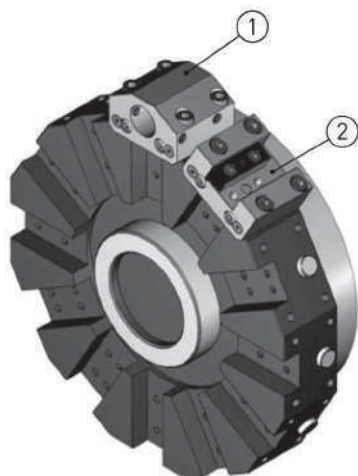

12

REFERENCIA	HASS	D	H	L	REFRIGERACIÓN	
					INTERNA	EXTERNA
TOIH3C32	BOT10MID-32	32	25.40	75	X	✓
TOIH3C32R	BOT10MID-32	32	25.40	75	✓	✓

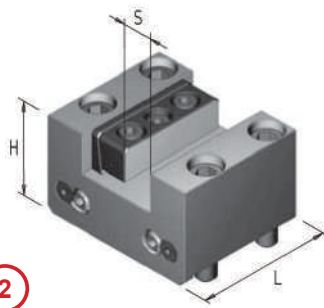
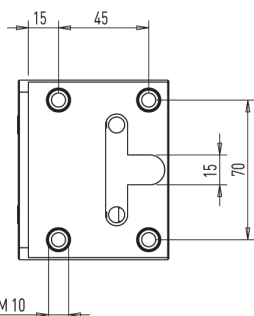

REFERENCIA	HASS	S	H	L	REFRIGERACIÓN	
					INTERNA	EXTERNA
TOEH3C40	BOT10MFG	20X20	40	75	X	✓

OKUMA

MODELOS

LB2000 EX/LB2500 EX/LB3000 EX (M-MW-MY-MYW)

LU2000 EX/LU2500 EX/LU3000 EX (M-MW-MY)

GENOS L300 (MY-MW-MYW)

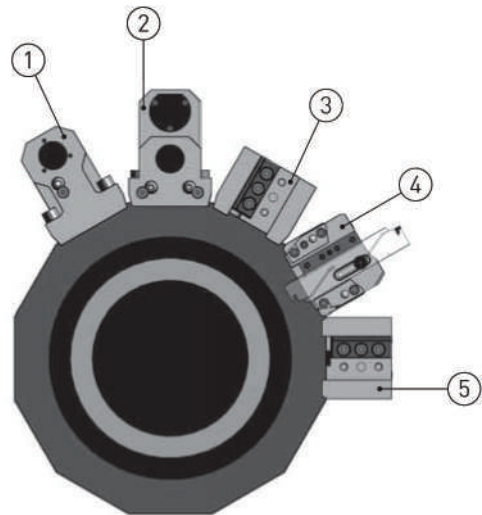
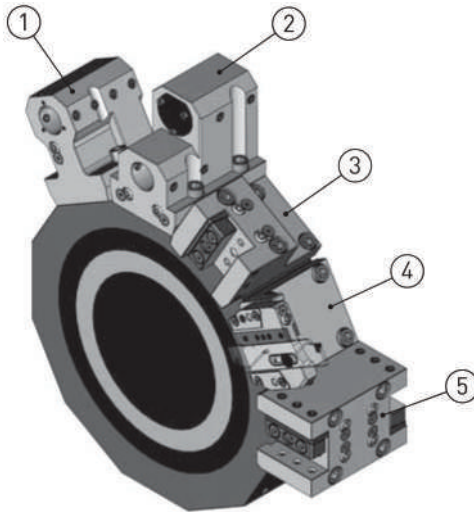
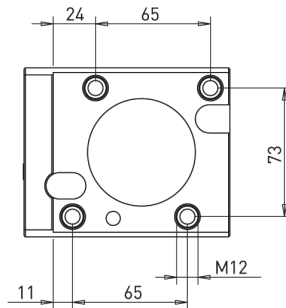

OKUMA

MODELOS

LB2000 EX/LB2500 EX/LB3000 EX (M-MW-MY-MYW)

LU2000 EX/LU2500 EX/LU3000 EX (M-MW-MY)

GENOS L300 (MY-MW-MYW)

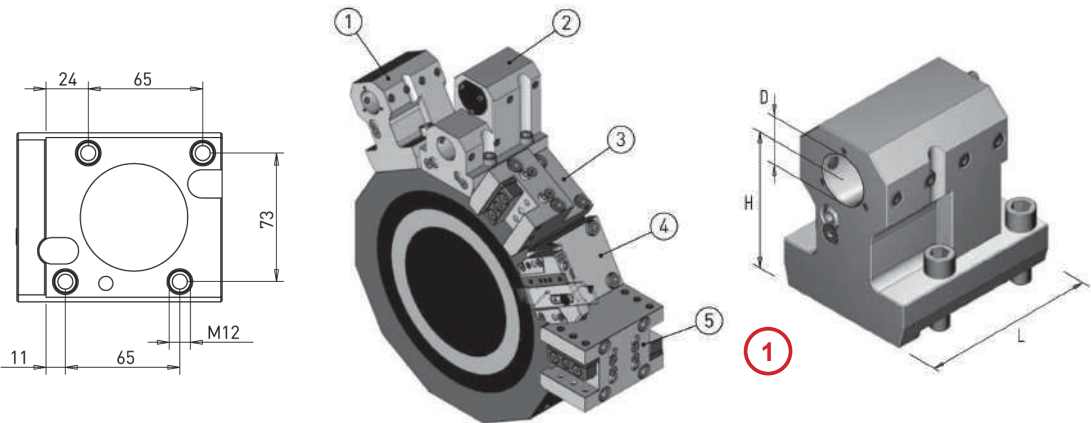

REFERENCIA	OKUMA	D	H	L	REFRIGERACIÓN	
					INTERNA	EXTERNA
TOIK6C32H90	/	32	90	116	X	✓
TOIK6C32RH90	/	32	90	116	✓	✓
TOIK6C40H90	/	40	90	116	X	✓
TOIK6C40RH90	/	40	90	116	✓	✓

12

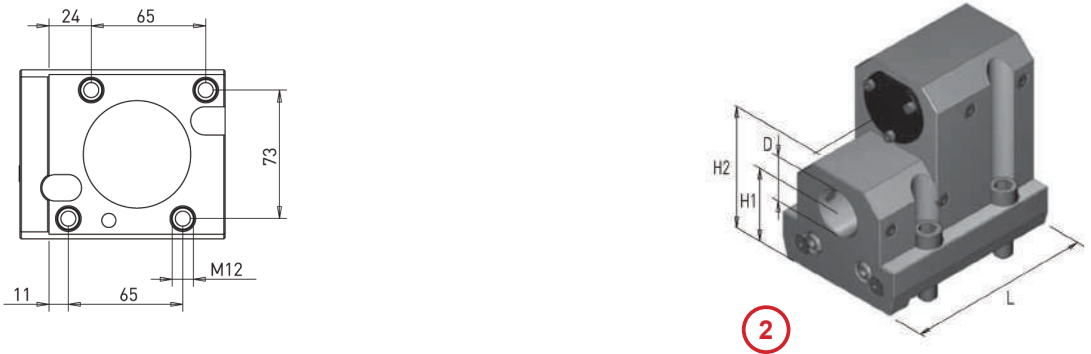

REFERENCIA	OKUMA	D	H1	H2	L	REFRIGERACIÓN	
						INTERNA	EXTERNA
TOIK6D32	/	32	50	105	133	X	✓
TOIK6D32R	/	32	50	105	133	✓	✓
TOIK6D40	/	40	50	105	133	X	✓
TOIK6D40R	/	40	50	105	133	✓	✓

OKUMA

MODELOS

LB2000 EX/LB2500 EX/LB3000 EX (M-MW-MY-MYW)

LU2000 EX/LU2500 EX/LU3000 EX (M-MW-MY)

GENOS L300 (MY-MW-MYW)

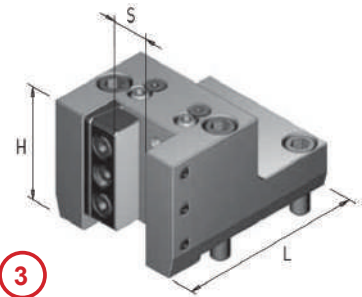
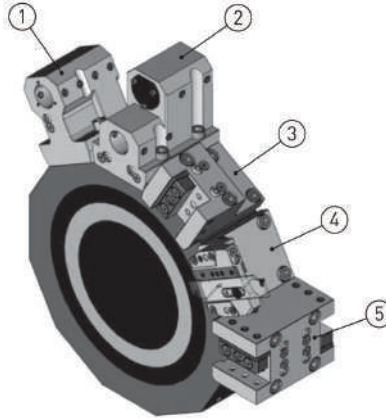
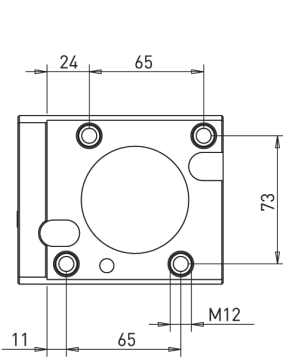

REFERENCIA	OKUMA	S	H	L	REFRIGERACIÓN	
					INTERNA	EXTERNA
TOEK6V50	/	25X25	75	126	X	✓

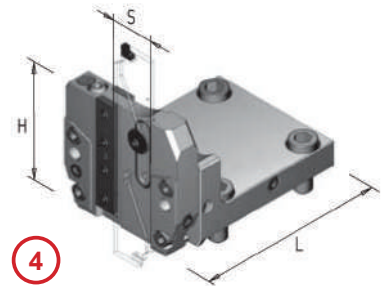
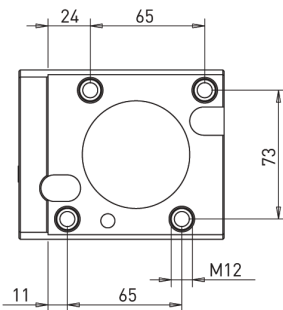

REFERENCIA	OKUMA	D	H	L	REFRIGERACIÓN	
					INTERNA	EXTERNA
TOEK6B32	/	ISCAR32	85	126	✓	✓

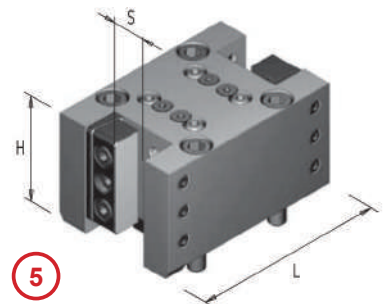
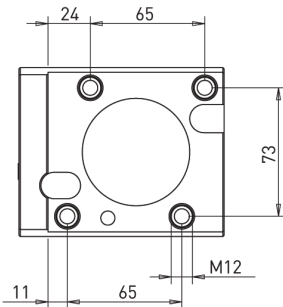

REFERENCIA	OKUMA	D	H	L	REFRIGERACIÓN	
					INTERNA	EXTERNA
TOEK6D50	/	25X25	75	152	X	✓

12

MURATEC

MODELOS

MT 12

MT 200

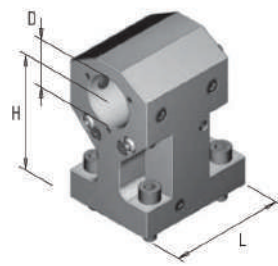
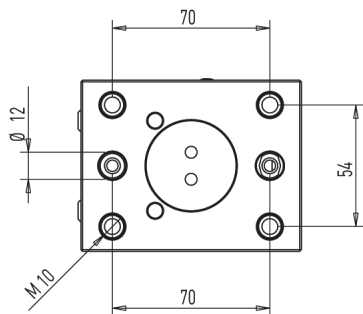
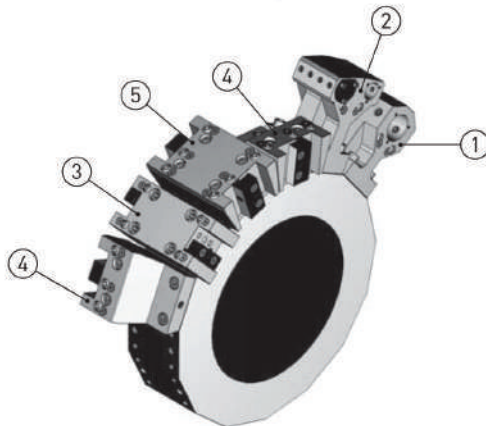

1

REFERENCIA	MURATEC	D	H	L	REFRIGERACIÓN	
					INTERNA	EXTERNA
TOIMU5C40H100	/	40	100	98	✓	✓

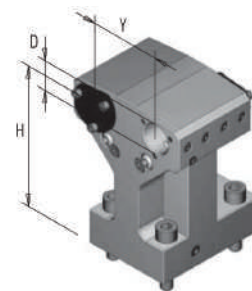
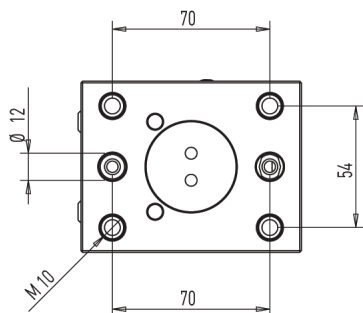

2

REFERENCIA	MURATEC	D	H	Y	REFRIGERACIÓN	
					INTERNA	EXTERNA
TOIMU5D25Y60	/	25	125	60	✓	✓

MURATEC

MODELOS

MT 12

MT 200

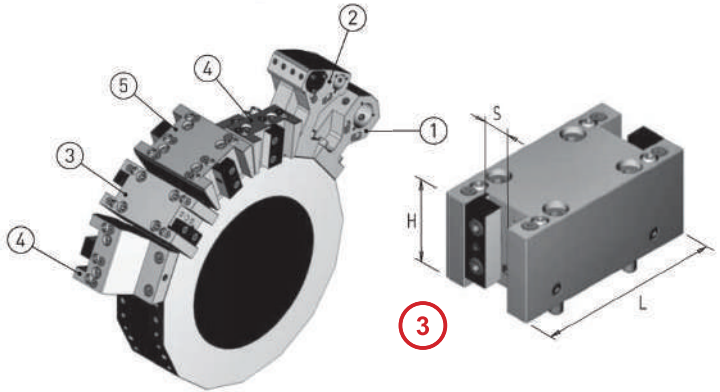
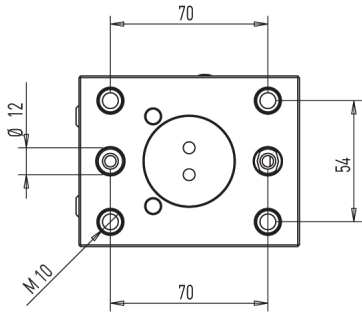

REFERENCIA	MURATEC	S	H	L	REFRIGERACIÓN	
					INTERNA	EXTERNA
TOEMU5D40	/	20X20	69	150	X	✓

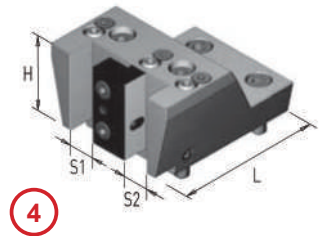
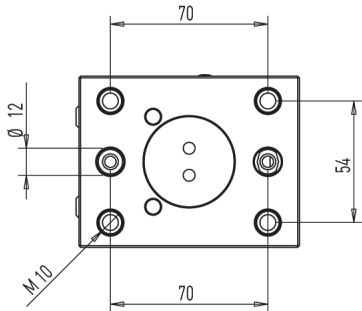

REFERENCIA	MURATEC	S1	S2	H	L	REFRIGERACIÓN	
						INTERNA	EXTERNA
TOEMU5V20D	/	20X20	20X20	69	124	X	✓

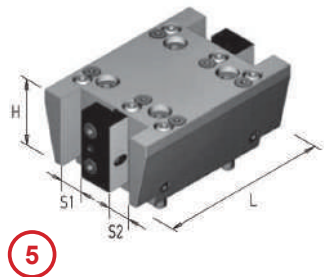
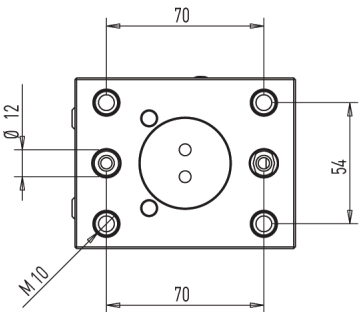

REFERENCIA	MURATEC	S1	S2	H	L	REFRIGERACIÓN	
						INTERNA	EXTERNA
TOEMU5D20Q	/	20X20	20X20	69	150	X	✓

GOODWAY

MODELOS

GLS 150 SERIES

GLS 200 SERIES

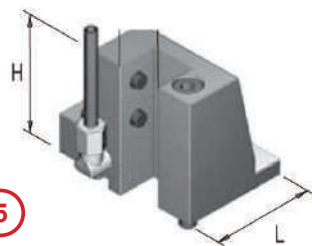
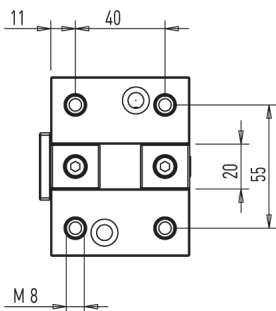
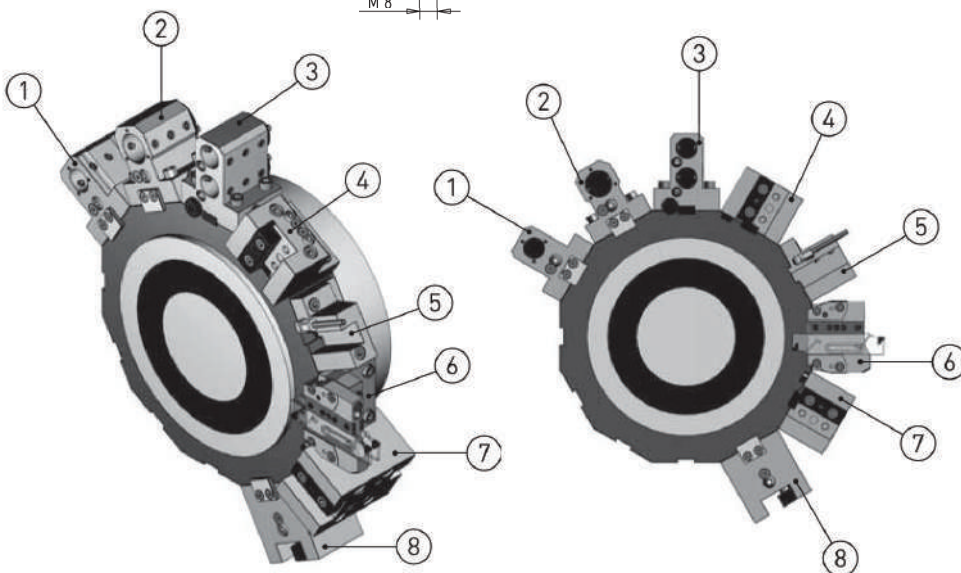
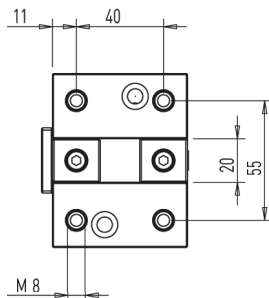

REFERENCIA	GOOGWAY	S	H	L	REFRIGERACIÓN	
					INTERNA	EXTERNA
TOEG3T20C	/	20X20	63	55	x	✓

Para porta herramientas 1 / 2 / 3 / 4 / 6 / 8 consultar pag. 49 a 51

Portas NAKAMURA tipo: TOIN3... TOEN3...

For toolholder 1 / 2 / 3 / 4 / 6 / 8 see pag. 49-51

NAKAMURA type: TOIN3... TOEN3...

GOODWAY

MODELOS

GA 200/260/280

GS 200/230/260/280

GA 2000/2600/2800/3000/3300/3600

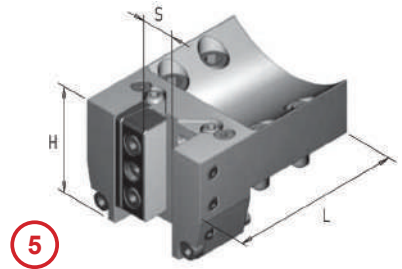
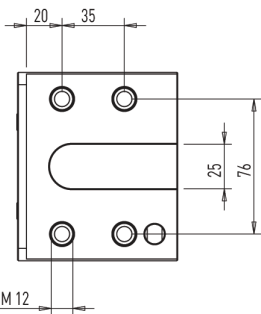
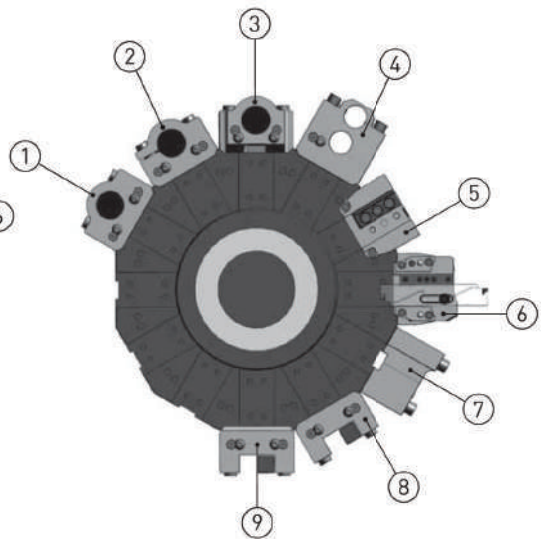
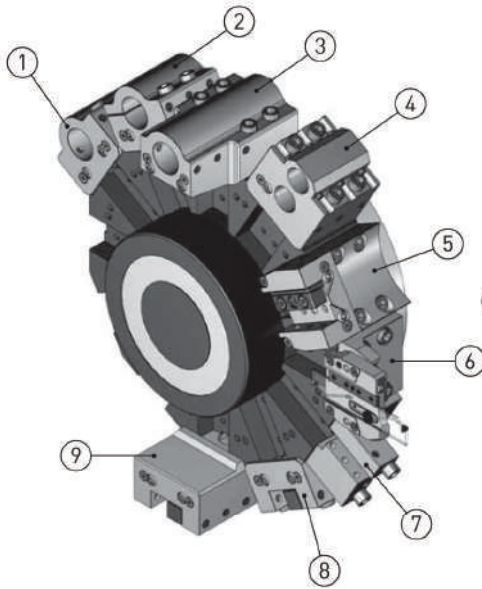
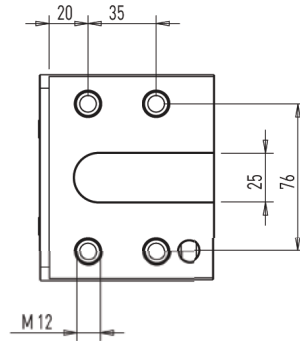

12

REFERENCIA	GOOGWAY	S	H	L	REFRIGERACIÓN	
					INTERNA	EXTERNA
TOEG6T50	/	25X25	82	130	x	✓

Para porta herramientas 1 / 2 / 3 / 4 / 6 / 8 / 9 consultar pag. 18 a 21

Portas MORI SEIKI / DMG MORI tipo: TOIM6... TOEM6...

For toolholder 1 / 2 / 3 / 4 / 6 / 8 see pag. 18-21

MORI SEIKI / DMG MORI type: TOIM6... TOEM6...

Recambios y Accesorios para P. Herramientas

Bloque de fijación en torreta y Porta herramientas

Locking blocks for tool fastening in turrets and toolholders

REFERENCIA	S	L	I	Porta Herramientas
E999005	25	109	50	TOEM6T50 - TOEM6T50L
E999013	25	70	40	TOEM8V50 - TOEM8C50 - TOEM8D50
E999013H	25	48	29	TOIH6C32 - TOIH6C40 - TOIH6C50
E999017	20	63	36	TOEM8V40 - TOEM8C40 - TOEM8D40
E999024	25	64	40	TOED6V50 - TOED6D50
E999026	20	60	32	TOEB6V40 - TOEB6D40 - TOEB6C40 - TOEB6V50L TOEN3V40 - TOEN3D40 - TOEN3C40 TOEN4V40 - TOEN4D40 - TOEN4C40
E999028	16	45	28	TOEB4V32 - TOEB4D32 - TOEB4C32 - TOEB4V32L

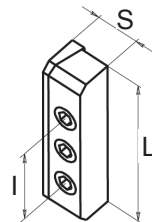

Bloque de fijación en Porta herramientas
Locking blocks for tool fastening in toolholders

REFERENCIA	S	L	Porta Herramientas
E999010	18	50	TOEM3D40 - TOEM8D40
E999009	18	79	TOEM3C40 - TOEM3L40 - TOEM8C40
E999008	24	60	TOEM6D50 - TOEM8D50 - TOEM8V50
E999004	24	90	TOEM6C50 - TOEM6L50 - TOEM6V50 TOEM6V50L - TOEM8V50L

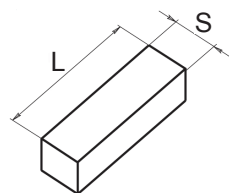

Placa de reducción de 25 a 20
Tool reduction plate from 25 to 20

REFERENCIA	S	L	H
E999021	24.5	19.5	90

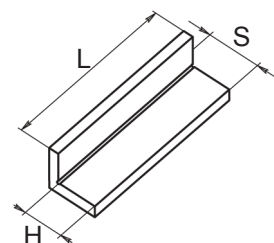

Para portaherramientas
For toolholders

REFERENCIA	S	FIG
E999012B	TOID6.D25	2
E999023	TOID6.C40	2

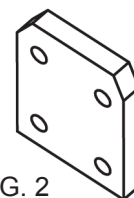
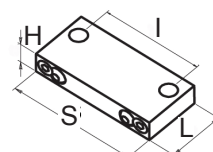

FIG. 2

Bloque para paso refrigerante
Coolant plate

REFERENCIA	REF. HASS	FAM	S	L	H	I
E999018B	CB10	6	88	45	16.5	70



Recambios y Accesorios para P. Herramientas

Bloque para desviación del refrigerante
Coolant deviation plate

REFERENCIA	REF. Mori Seiki	FAM	S	L	H
E999018	B52059	6	65	40	12

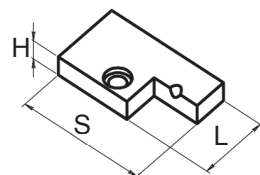

Tapa refrigeración interna
Ring for inner coolant feeding system

REFERENCIA	D	Agujero
E999012	40	25
E999001	48	32
E999002	60	40
E999007	70	50

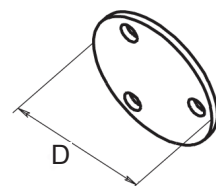

Tapa Porta herramientas
Ring for toolholders

REFERENCIA	D	H
E999016	60	25
E999016B	40	25

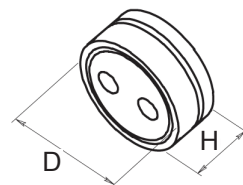

Tubo cobre para refrigerante
Copper coolant pipe

REFERENCIA	D	L	F	R
E999015	6	100	1/8	Recto
E999015B	6	100	1/8	90°

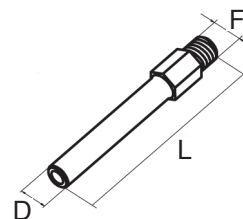

Esferas para refrigeración
Cooling direction balls

REFERENCIA	D
E999003	14
E999003C	12
E999003D	10

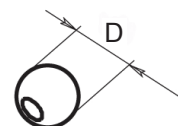

Porta herramientas Radial DIN/69881 VDI 3425 Forma A
Turning toolholders Radial DIN/69881 VDI 3425 Form A

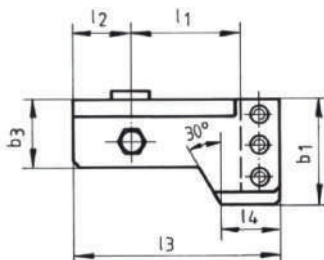
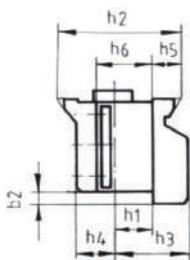

A2= Derecha / Right

REFERENCIA	COD	h1	h2	b1	b2	b3	h3	h4	h5	h6	I1	I2	I3	I4
A2-56x16	10.100	16	56	50	6	32	40	19	12	22	49	31	94	34
A2-72x20	10.110	20	72	63	6	40	43	27	16	29	49	39	110	45
A2-90x25	10.120	25	90	72	9	40	50	35.5	20	34	73	39	138	45
A2-115x32	10.130	32	115	85	9	50	60	40	25.5	41	112	49	191	50
A2-140x40	10.140	40	140	110	12	60	78	57.5	30	53	115	59	209	58

A1= Izquierda / Left

A1-56x16	10.101	16	56	50	6	32	40	19	12	22	49	31	94	34
A1-72x20	10.111	20	72	63	6	40	43	27	16	29	49	39	110	45
A1-90x25	10.121	25	90	72	9	40	50	35.5	20	34	73	39	138	45
A1-115x32	10.131	32	115	85	9	50	60	40	25.5	41	112	49	191	50
A1-140x40	10.141	40	140	110	12	60	78	57.5	30	53	115	59	209	58

Porta herramientas Axial DIN/69881 VDI 3425 Forma B
Turning toolholders Axial DIN/69881 VDI 3425 Form B

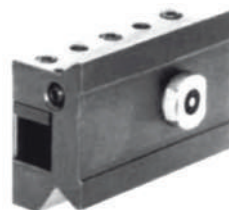
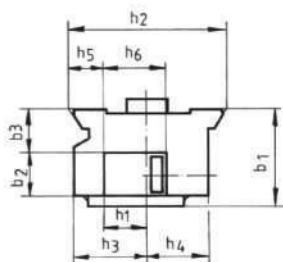
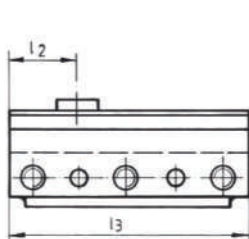

B1= Derecha / Right

REFERENCIA	COD	h1	h2	b1	b2	h3	h4	h5	h6	I1	I2	I3
B1-56x16	10.150	16	56	39	20	16	26	19	12	22	31	94
B1-72x20	10.160	20	72	47	26	16	34	27	16	29	39	110
B1-90x25	10.170	25	90	49	26	18	42.5	35.5	20	34	39	118
B1-115x32	10.180	32	115	56	33	18	55	40	25.5	41	49	123
B1-140x40	10.190	40	140	67	42	20	67.5	57.5	30	53	59	160

B2= Izquierda / Left

B2-56x16	10.151	16	56	39	20	16	26	19	12	22	31	94
B2-72x20	10.161	20	72	47	26	16	34	27	16	29	39	110
B2-90x25	10.171	25	90	49	26	18	42.5	35.5	20	34	39	118
B2-115x32	10.181	32	115	56	33	18	55	40	25.5	41	49	123
B2-140x40	10.191	40	140	67	42	20	67.5	57.5	30	53	59	160

Porta herramientas Cuadrado universal Forma C
Multi purpose square toolholders Form C

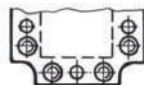
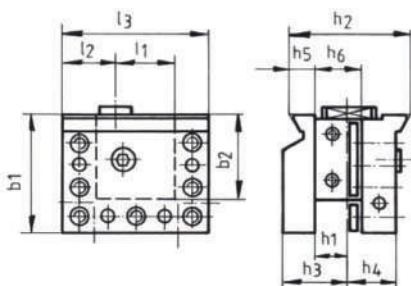

C1= Derecha / Right

REFERENCIA	COD	h1	h2	b1	b2	h3	h4	h5	h6	I1	I2	I3
C1D56x16	10.200	16	56	60	46	40	19	12	22	39	31	84
C1D72x20	10.210	20	72	81	59	43	27	16	29	37	39	98
C1D90x25	10.220	25	90	88	62	50	35.5	20	34	43	39	108
C1D115x32	10.230	32	115	94	68	60	40	25.5	41	43	49	118
C1D140x40	10.240	40	140	115	83	78	57.5	30	53	53	59	144

C2= Izquierda / Left

C2D56x16	10.201	16	56	60	46	40	19	12	22	39	31	84
C2D72x20	10.211	20	72	81	59	43	27	16	29	37	39	98
C2D90x25	10.221	25	90	88	62	50	35.5	20	34	43	39	108
C2D115x32	10.231	32	115	94	68	60	40	25.5	41	43	49	118
C2D140x40	10.241	40	140	115	83	78	57.5	30	53	53	59	144

Porta herramientas Cuadrado universal reducido Forma C3
Multi purpose square toolholders narrow Form C3

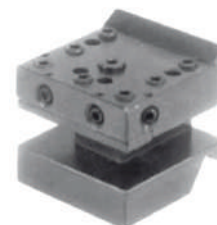
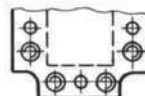
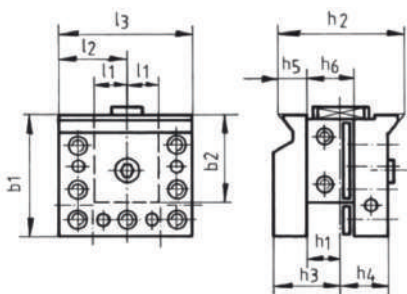

REFERENCIA	COD	h1	h2	b1	b2	b3	h3	h4	h5	h6	I1	I4
C3D56x16	10.250	16	56	60	46	40	19	12	22	17	31	62
C3D72x20	10.260	20	72	81	59	43	27	16	29	17	39	78
C3D90x25	10.270	25	90	88	62	50	35.5	20	34	23	49	98
C3D115x32	10.280	32	115	94	68	60	40	25.5	41	23	49	98
C3D140x40	10.290	40	140	115	83	78	57.5	30	53	27	59	118



Porta herramientas Radial doble Forma C4
Double-Radial toolholders Form C4

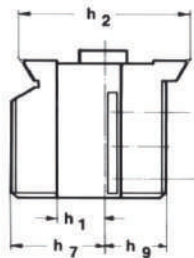
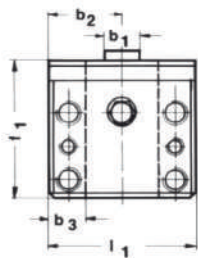

REFERENCIA	COD	h1	b1	b2	b3	h2	h7	h9	f1	l1
C4D56x16	10.300	16	16	34	16	56	40	19	60	68
C4D72x20	10.310	20	20	39	22	72	43	27	81	78
C4D90x25	10.320	25	25	39	25	90	50	35.5	88	78
C4D115x32	10.330	32	25	49	26	115	60	40	94	98
C4D115x40	10.340	40	25	59	32	140	78	57.5	115	118

Porta herramientas Cilíndrico Forma D3
Side lock adaptor Form D3

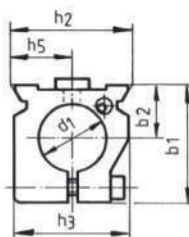
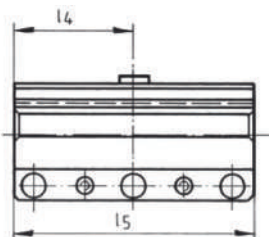

REFERENCIA	COD	h2	d1	b1	b2	h3	h5	l4	l5
D3D56x32	10.350	56	32	65	30	52	28	59	118
D3D56x40	10.355	56	40	65	30	52	28	59	118
D3D72x40	10.360	72	40	76	35	68	36	75	150
D3D72x50	10.365	72	50	76	35	68	36	75	150
D3D90x50	10.370	90	50	94	45	85	45	99	198
D3D90x60	10.375	90	60	94	45	85	45	99	198
D3D115x60	10.380	115	60	94	45	93	57.5	99	198
D3D115x80	10.385	115	80	115	55	115	57.5	99	198
D3D140x80	10.390	140	80	125	60	115	70	119	238
D3D140x100	10.395	140	100	145	70	135	70	119	238



Porta herramientas Cilíndrico corto Forma D
Side lock adaptor - short Form D

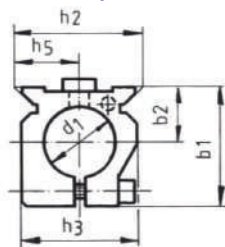
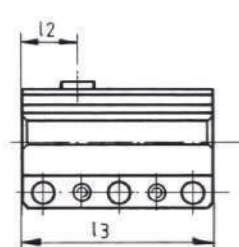

D2= Derecha / Right

REFERENCIA	COD	h2	d1	b1	b2	h3	h5	l2	l3
D2D56x32	10.400	56	32	65	30	52	28	31	94
D2D56x40	10.450	56	40	65	30	52	28	31	94
D2D72x40	10.410	72	40	76	35	68	36	39	110
D2D72x50	10.460	72	50	76	35	68	36	39	110
D2D90x50	10.420	90	50	94	45	85	45	39	138
D2D90x60	10.470	90	60	94	45	85	45	39	138
D2D115x60	10.430	115	60	94	45	93	57.5	49	148
D2D115x80	10.480	115	80	94	55	115	57.5	49	148
D2D140x80	10.440	140	80	125	60	115	70	59	178
D2D140x100	10.490	140	100	125	70	135	70	59	178

D1= Izquierda / Left

D1D56x32	10.401	56	32	65	30	52	28	31	94
D1D56x40	10.451	56	40	65	30	52	28	31	94
D1D72x40	10.411	72	40	76	35	68	36	39	110
D1D72x50	10.461	72	50	76	35	68	36	39	110
D1D90x50	10.421	90	50	94	45	85	45	39	138
D1D90x60	10.471	90	60	94	45	85	45	39	138
D1D115x60	10.431	115	60	94	45	93	57.5	49	148
D1D115x80	10.481	115	80	94	55	115	57.5	49	148
D1D140x80	10.441	140	80	125	60	115	70	59	178
D1D140x100	10.491	140	100	125	70	135	70	59	178

Porta herramientas para barras de mandrinar
Boring bar holders

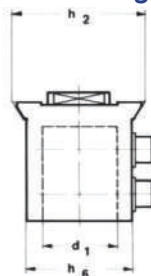
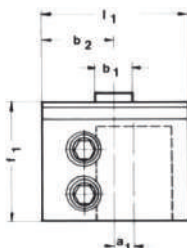

REFERENCIA	h2	d1	a1	b1	b2	h6	f1	l1
10500	56	32	8	16	34	39	54	68
10510	72	40	10	20	39	53	65	78
10520	90	50		25	59	71	80	98
10530	115	60	12.5	25	49	95	94	98
10540	140	80	12.5	25	59	115	120	118

Distribuidor refrigerante
Coolant distribuidor

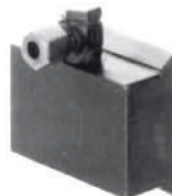
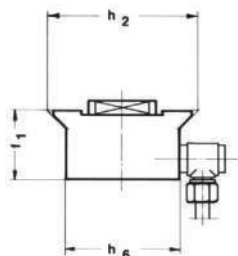
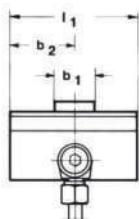

REFERENCIA	h2	b1	b2	h6	f1	l1
10550	56	16	34	39	28	68
10560	72	20	39	53	34	78
10570	90	25	39	71	42	78
10580	115	25	49	95	54	98
10590	140	25	59	115	60	118

Porta herramientas para casquillo de regulación DIN/6327
Automotive sleeves DIN/6327

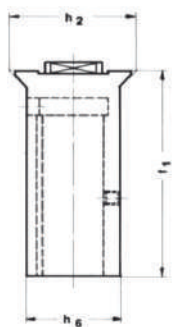
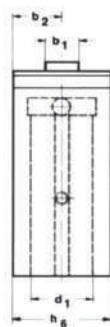

REFERENCIA	h2	d1	b1	b2	h6	f1
10600	56	36	16	26	52	120
10610	72	36	20	26	52	120
10620	90	48	25	35.5	71	140
10630	115	48	25	47.5	95	140
10640	140	48	25	57.5	115	140

Porta herramientas para casquillo de regulación DIN/6327
Automotive sleeves DIN/6327

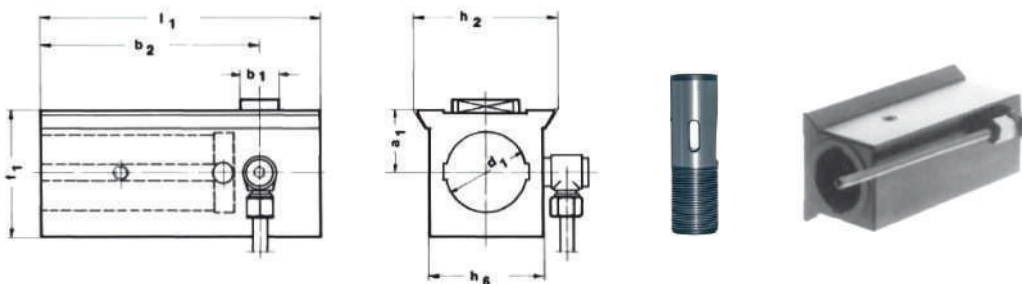

REFERENCIA	h2	d1	b1	b2	h6	f1	l1	a1
10650	56	36	16	90	52	58	119	30
10660	72	36	20	100	52	58	139	30
10670	90	48	25	135	71	80	174	40
10680	115	48	25	175	95	80	224	40
10690	140	48	25	175	115	80	224	40

Porta herramientas Multiple
Multi-toolholder

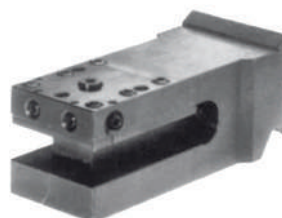
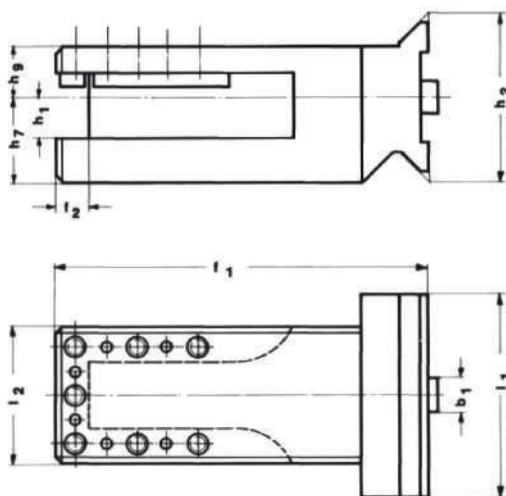

REFERENCIA	h1	h2	h7	h9	b1	f1	f2	l1	l2
10700	16	56	40	19	16	160	15	62	55
10710	20	72	42.5	26	20	180	18	82	70
10720	25	90	50	30	25	200	22	78	78
10730	32	115	60	40	25	220	28	118	98
10740	40	140	80	57	25	240	32	155	118

Porta herramientas de mandrinar Doble
Double-boring bar holder

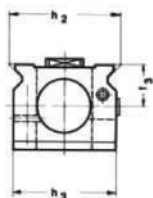
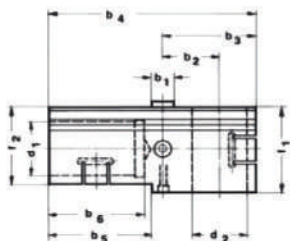

REFERENCIA	h2	d1	d2	h3	b1	b2	b3	b4	b5	b6	f1	f2	f3
10760	72	40	40	68	20	40	75	175		80	70	70	35
10770	90	50	50	85	25	45	80	210	120	110	85	75	40
10780	115	60	60	110	25	62.5	102	227	150	125	94	85	45
10790	140	80	80	135	25	65	120	300	170	150	125	115	60

Soporte porta herramientas
Toolholder plate

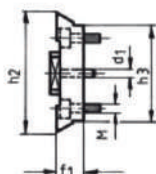
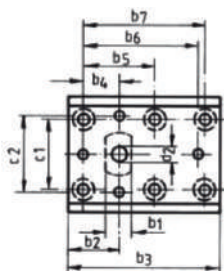

REFERENCIA	h2	h3	b1	b2	b3	b4	b5	b6	b7	c1	c2	f1	M	d1	d2
10810	72	53	20	39	98	25			70	30	40	20	M8	6	13
10820	90	71	25	39	115	25	50	87	87	55	55	55	M10	8	15
10830	115	95	25	49	148	35	70	115	120	70	70	25	M10	8	15
10840	140	115	25	59	200	45	90	172	172	90	90	35	M12	10	15

Soporte porta herramientas corto
Toolholder plate short

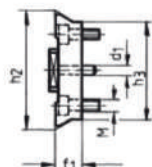
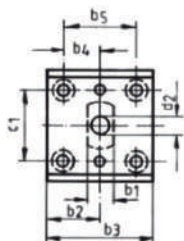

REFERENCIA	h2	h3	b1	b2	b3	b4	b5	c1	f1	M	d1	d2
10815	72	53	20	39	78	25	50	30	20	M8	6	13
10825	90	71	25	39	78	25	50	55	25	M10	8	15
10835	115	95	25	49	98	35	70	70	25	M10	8	15
10845	140	115	25	59	160	45	132	90	35	M12	10	15

Porta herramientas para broca con plaquita
Boring holder for carbide tip boring

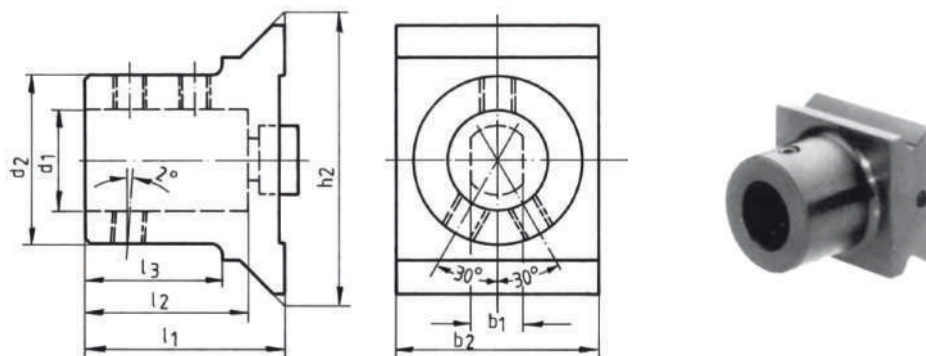

REFERENCIA	h2	d1	b1	b2	d2	l1	l2	l3
10900/20	56	20	16	68	44	66	54	44
10900/25	56	25	16	68	49	71	59	49
10900/32	56	32	16	68	56	75	63	54
10900/40	56	40	16	68	64	85	73	60
10910/20	72	20	20	78	44	66	54	44
10910/25	72	25	20	78	49	71	59	49
10910/32	72	32	20	78	56	75	63	54
10910/40	72	40	20	78	64	85	73	60
10910/50	72	50	20	78	74	95	83	70
10920/20	90	20	25	98	44	66	54	44
10920/25	90	25	25	98	49	71	59	49
10920/32	90	32	25	98	56	75	63	54
10920/40	90	40	25	98	64	85	73	60
10920/50	90	50	25	98	74	95	83	70
10930/20	115	20	25	98	44	66	54	44
10930/25	115	25	25	98	49	71	59	49
10930/32	115	32	25	98	56	75	63	54
10930/40	115	40	25	98	64	85	73	60
10930/50	115	50	25	98	74	95	83	70
10940/20	140	20	25	118	44	66	54	44
10940/25	140	25	25	118	49	71	59	49
10940/32	140	32	25	118	56	75	63	54
10940/40	140	40	25	118	64	85	73	60
10940/50	140	50	25	118	74	95	83	70



Porta herramientas para broca con plaquita
Boring holder for carbide tip boring

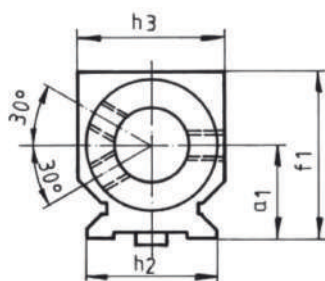
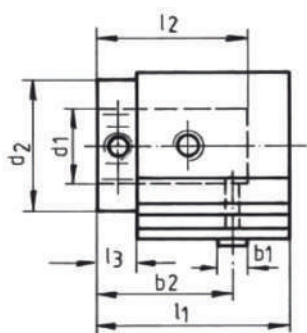

REFERENCIA	h2	d1	a1	b1	b2	d2	f1	h3	l1	l2	l3
10950/20	56	20	40	16	75	44	76	66	109	54	28
10950/25	56	25	40	16	75	49	76	66	109	59	28
10950/32	56	32	40	16	75	56	76	66	109	63	28
10950/40	56	40	40	16	75	64	76	66	109	73	32
10960/20	72	20	45	20	80	44	78	68	119	54	28
10960/25	72	25	45	20	80	49	78	68	119	59	28
10960/32	72	32	45	20	80	56	78	68	119	63	28
10960/40	72	40	45	20	80	64	78	68	119	73	32
10960/50	72	50	45	20	80	74	78	68	119	83	34
10970/20	90	20	50	25	100	44	86	80	139	54	28
10970/25	90	25	50	25	100	49	86	80	139	59	28
10970/32	90	32	50	25	100	56	86	80	139	63	28
10970/40	90	40	50	25	100	64	86	80	139	73	32
10970/50	90	50	50	25	100	74	86	80	139	83	34
10980/20	115	20	55	25	100	44	95	94	149	54	28
10980/25	115	25	55	25	100	49	95	94	149	59	28
10980/32	115	32	55	25	100	56	95	94	149	63	28
10980/40	115	40	55	25	100	64	95	94	149	73	32
10980/50	115	50	55	25	100	74	95	94	149	83	34
10990/20	140	20	60	25	120	44	100	114	189	54	28
10990/25	140	25	60	25	120	49	100	114	189	59	28
10990/32	140	32	60	25	120	56	100	114	189	63	28
10990/40	140	40	60	25	120	64	100	114	189	73	32
10990/50	140	50	60	25	120	74	100	114	189	83	34



Porta herramientas para mandrinado con regulación de Ø y centraje
 WH-toolholder for boring bars diameter and centre tooling adjustable

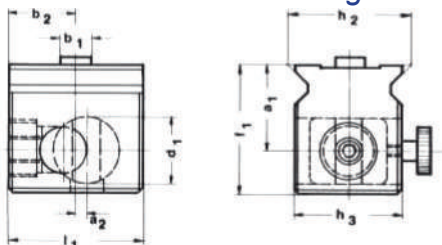

REFERENCIA	h2	d1	a1	a2	b1	b2	f1	h3	l1
30100	56	36	41	4	16	34	64	52	68
30110	72	46	48	6	20	38	76	66	78
30120	90	46	50	6	25	38	78	66	78
30130	115	46	52	6	25	38	80	66	78
30140	140	46	56	6	25	38	84	66	78

Porta herramientas para mandrinado con regulación de Ø y centraje
 WH-toolholder for boring bars diameter and centre tooling adjustable

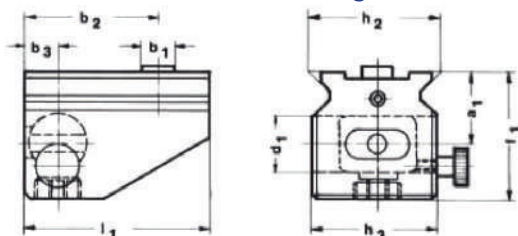

REFERENCIA	h2	d1	a1	b1	b2	b3	f1	h2	h3	l1
30150	56	36	39	16	59	23	77	56	52	93
30160	72	46	48	20	75	28	93	72	66	114
30170	90	46	50	25	89	28	95	90	66	138
30180	115	46	52	25	99	28	97	115	66	148
30190	140	46	55	25	119	28	100	140	66	188

12

Soportes intercambiables
 WH-infeed toolholders

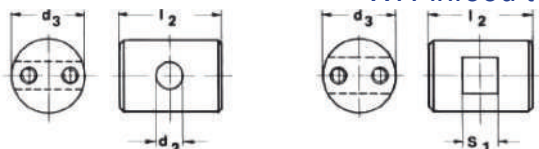

COD	d1	a1	l1	COD	d1	a1	l1	COD	d1	a1	l1
200208	36	8	38	200312	46	12	52	210312	46	12	52
200210	36	10	38	200313	46	13	52	210316	46	16	52
200212	36	12	38	200314	46	14	52	210320	46	20	52
200213	36	13	38	200315	46	15	52				
200214	36	14	38	200316	46	16	52				
200215	36	15	38	200320	46	20	52				
200216	36	16	38	200325	46	25	52				

